

Confocal Microscopy

By Ivan Rey

The Out of Focus Light Problem

In widefield, fluorescence from planes outside the focal plane adds background collected with the in-focus signal.

The extra background raises noise and lowers contrast, reducing the overall signal to noise ratio (SNR).

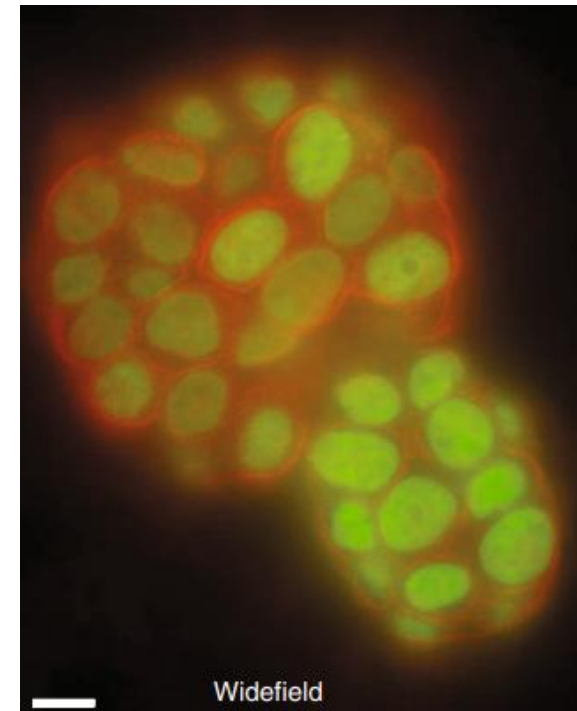
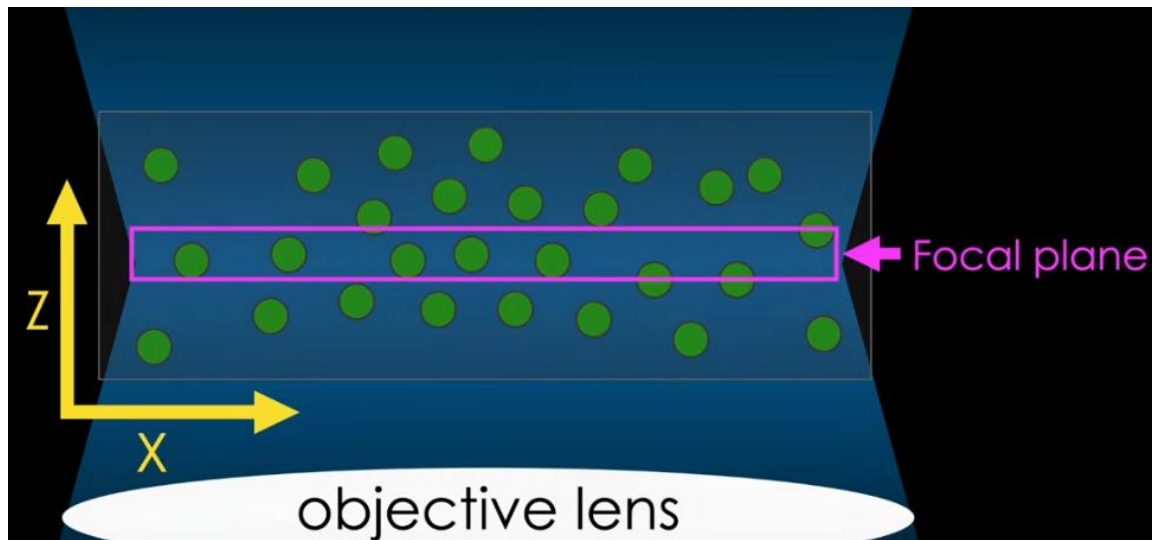

The Out of Focus Light Problem

Various optical and computational techniques have been developed to suppress out of focus light and restore image contrast and SNR.

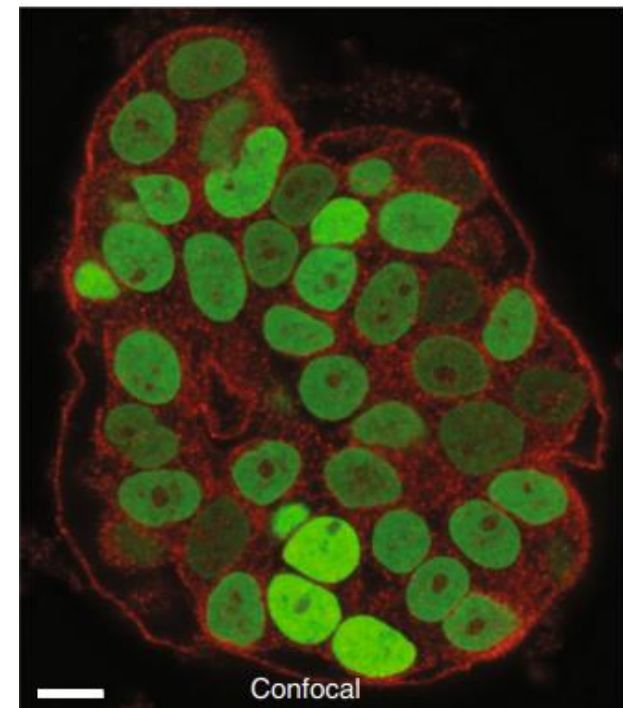
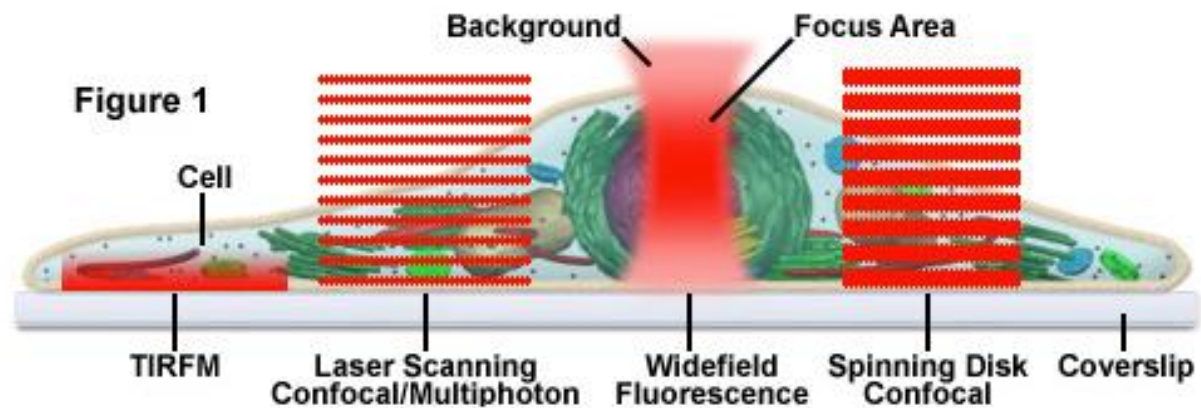

Outline

- **Optical sectioning techniques**

 - The point scanning confocal

 - Ribbon scanning confocal

 - Line scanning confocal

 - Image scanning confocal

 - Re-scanning confocal

 - Spinning disk confocal

 - Widefield Deconvolution Microscopy

 - Light sheet*

 - Multiphoton Microscopy*

- **Practical considerations for confocal imaging**

- **Applications of confocal microscopy**

- **The battle of the systems**

Optical Sectioning Techniques

Point scanning Confocal

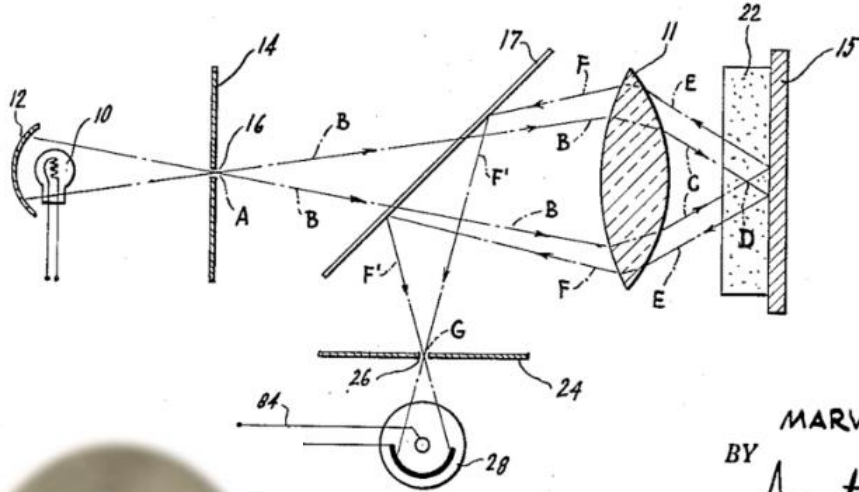
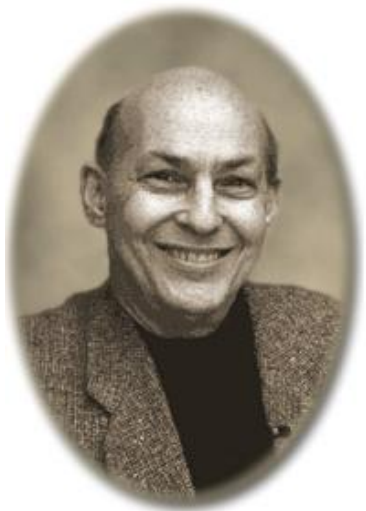

FIG. 3.

INVENTOR.
MARVIN MINSKY
BY *Ameter & Levy*
ATTORNEYS

The point scanning confocal was invented by Marvin Minsky in 1955.

The premise was a system that used spatial filtering to eliminate out of focus light in specimens that are thicker than the plane of focus.



Point scanning Confocal

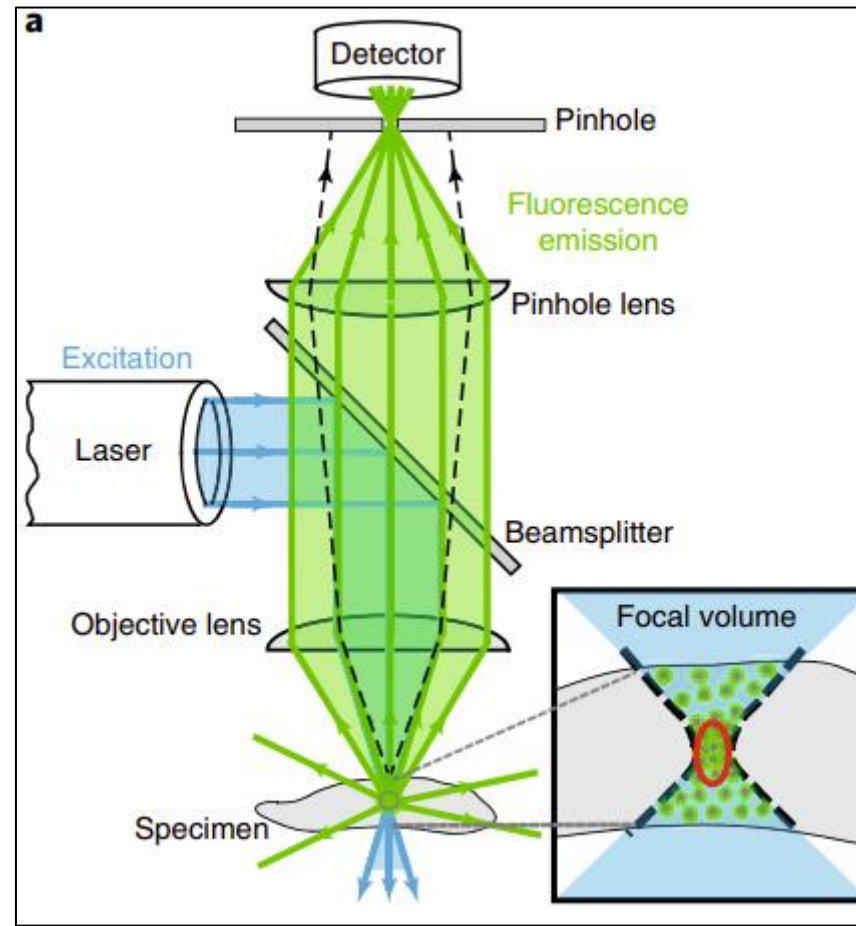

Point scanning Confocal - Illumination

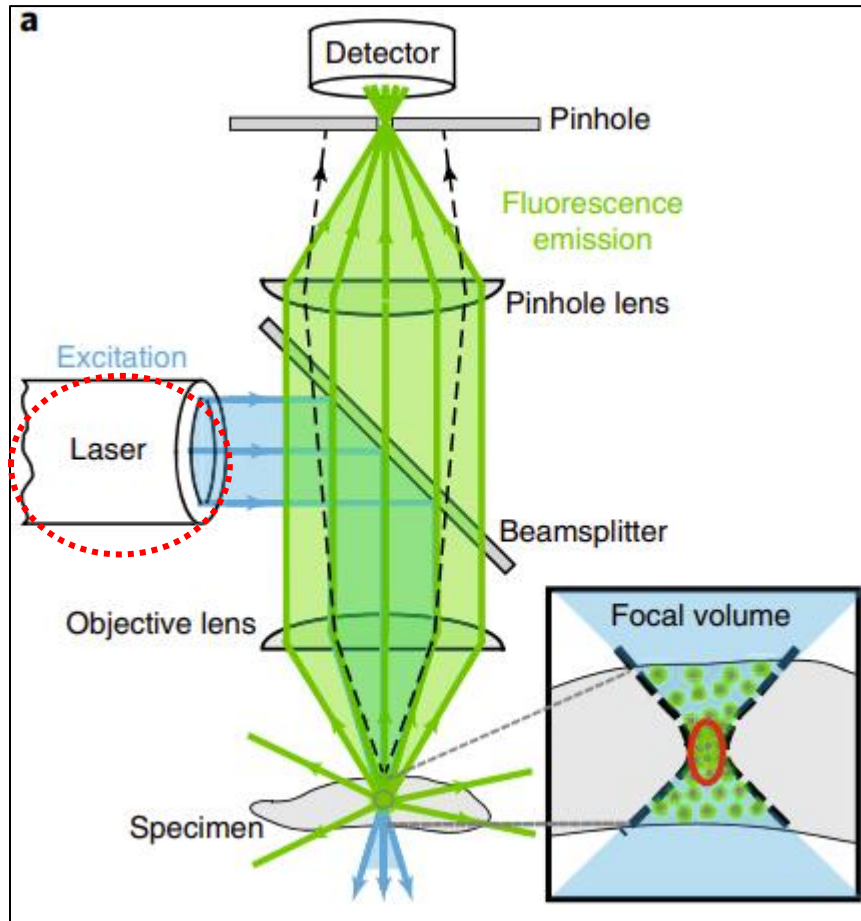

Acusto-optical tunable filters are used to direct several laser lines along the same optical path.

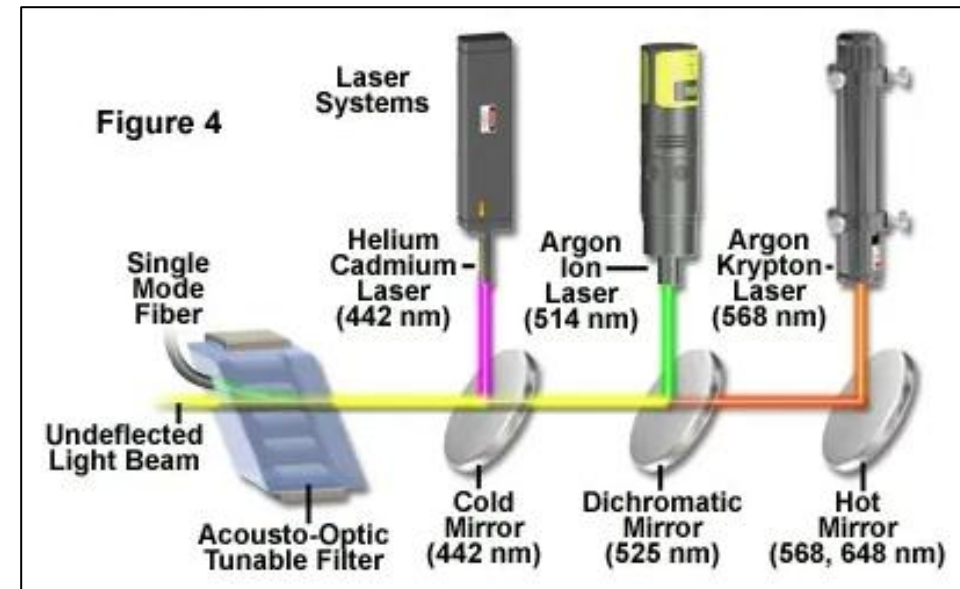

<https://evidentscientific.com/en/microscope-resource/knowledge-hub/techniques/confocal/aotfintro>

Point scanning Confocal - Illumination

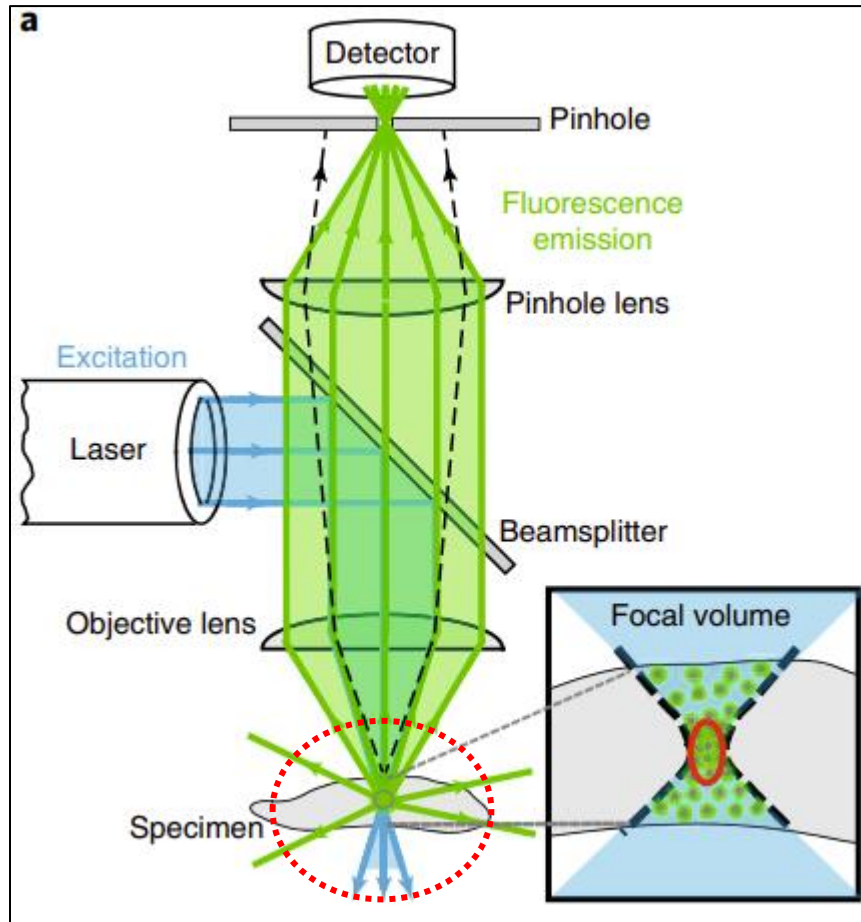

Notice that the light is focused into a much smaller spot that in widefield microscopy – this requires the use of a laser (coherent, collimated)

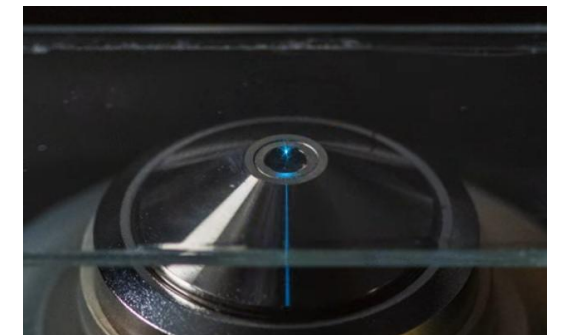
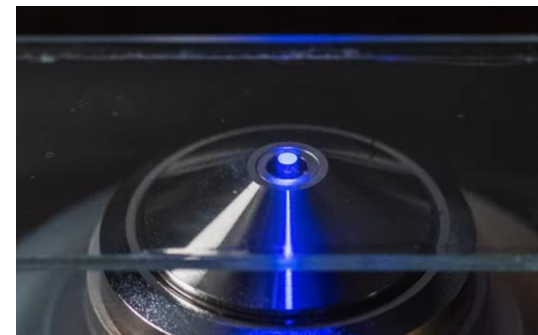
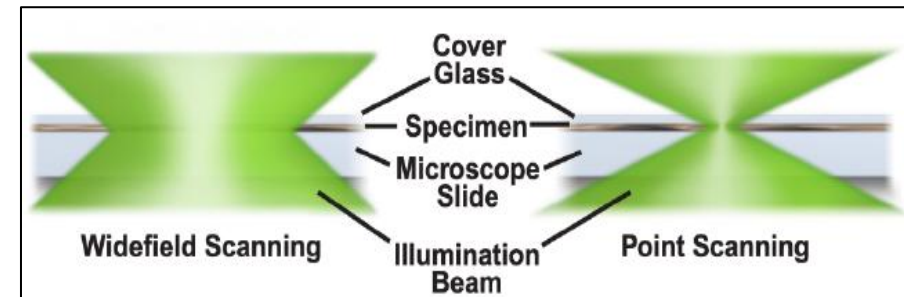

Point scanning Confocal - Galvos

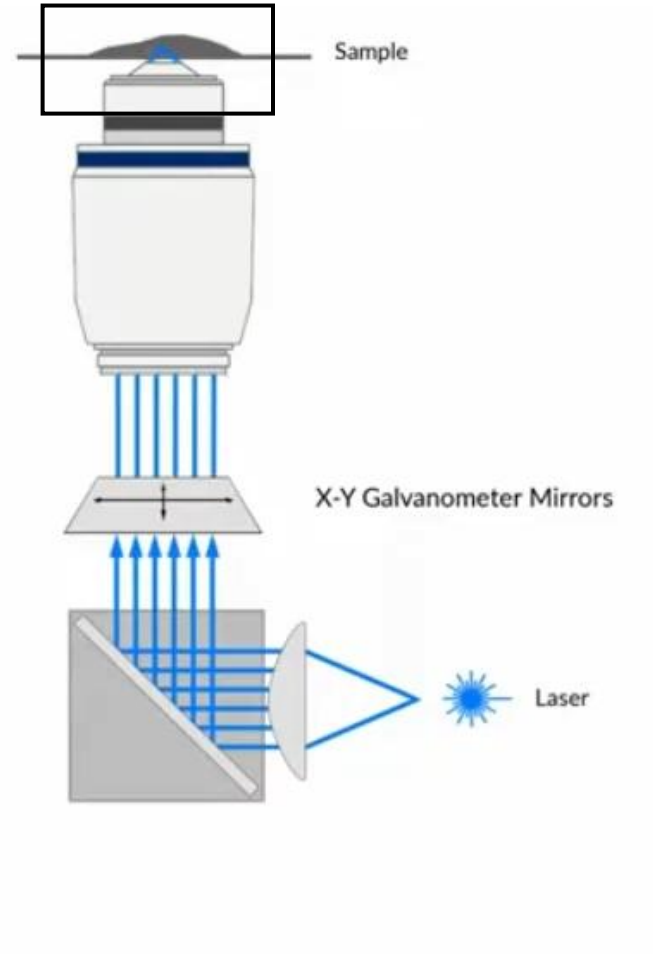
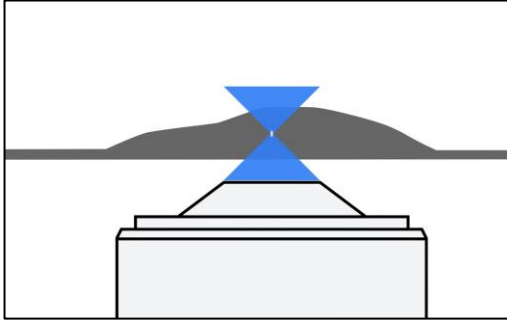

Movable mirrors are used to scan the laser over the sample

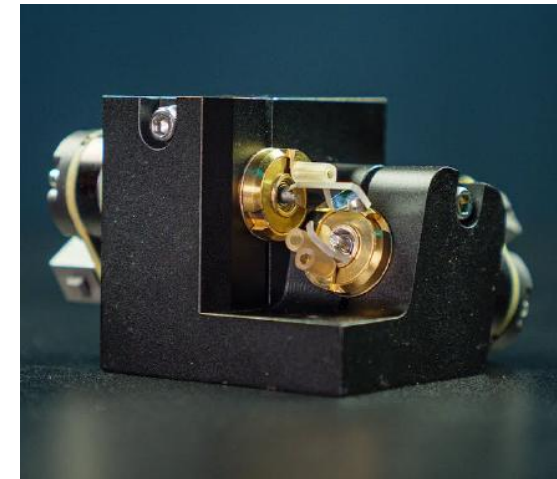

Point scanning Confocal - Galvos

- The amplitude of the sweep defines the Zoom factor (pixel size)
- The speed of the sweeping defines the pixel dwell time (will influence SNR)

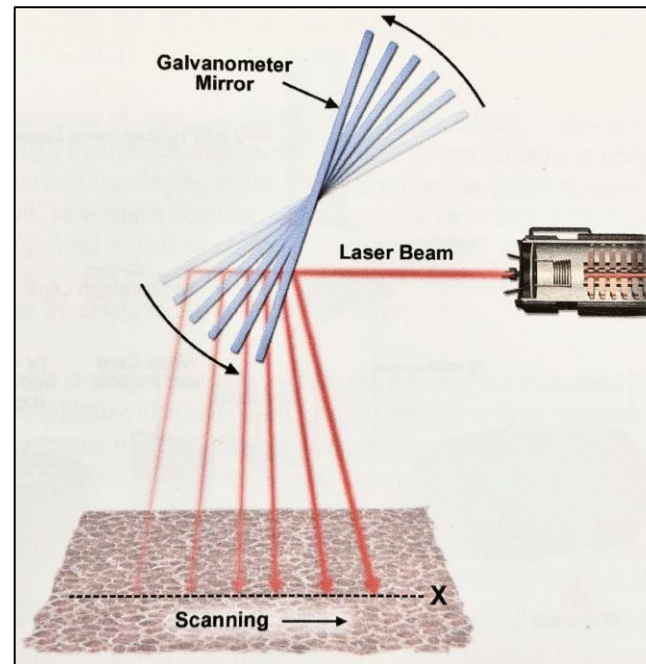

Point scanning Confocal – Resonant scanners

Resonant scanners are high quality mirrors that oscillate at a fixed mechanical resonance frequency (typically 8–16 kHz line rate).

The fixed frequency means that the dwell time is fixed as well.

Dwell time with this scanners is short – low SNR & fast scanning.



Point scanning Confocal – The lenses

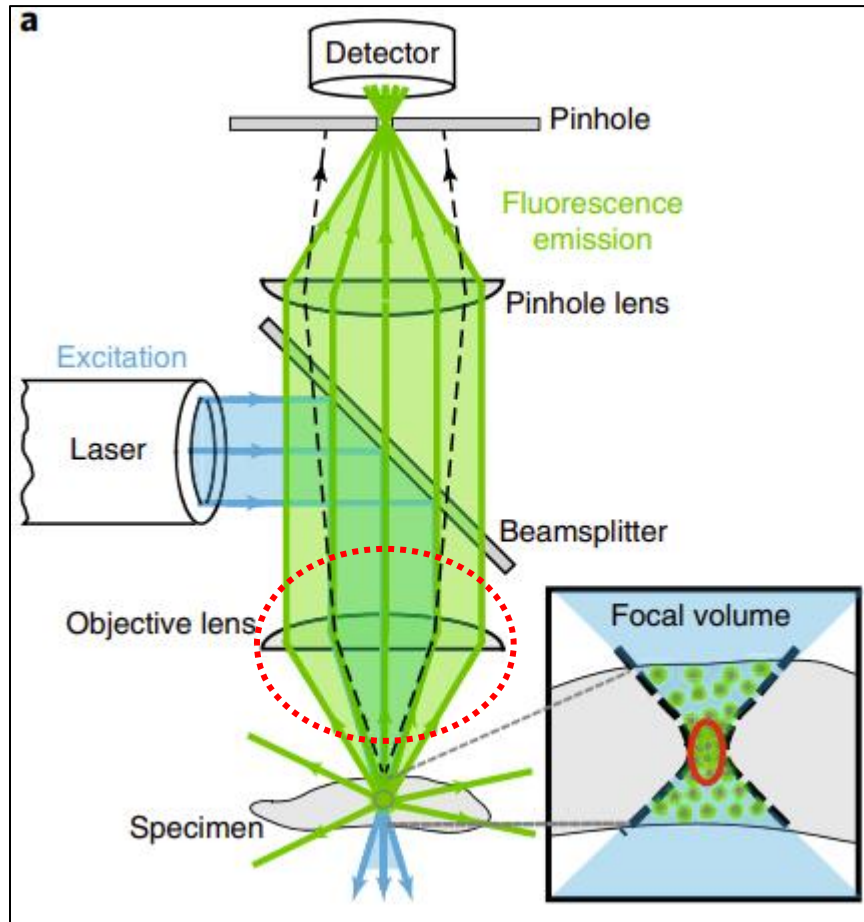

Lenses for confocal microscopy must perform over a wide range of wavelengths and have spherical, flat field and chromatic corrections.

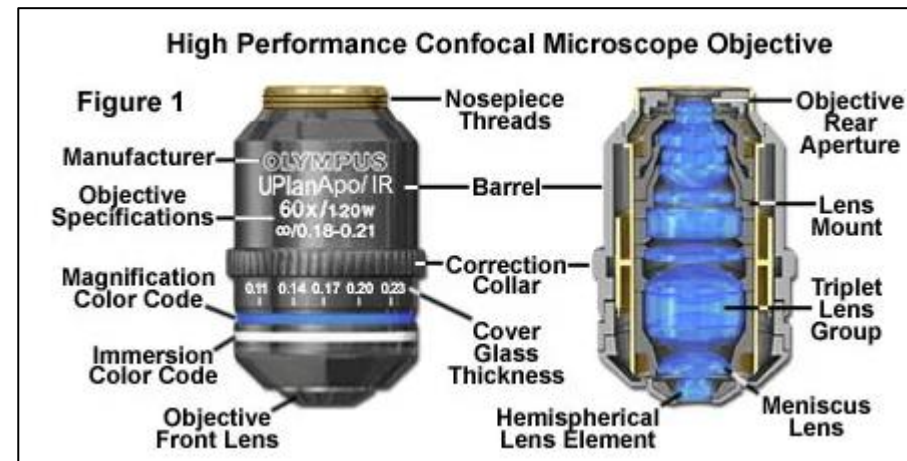

Point scanning Confocal – The lenses

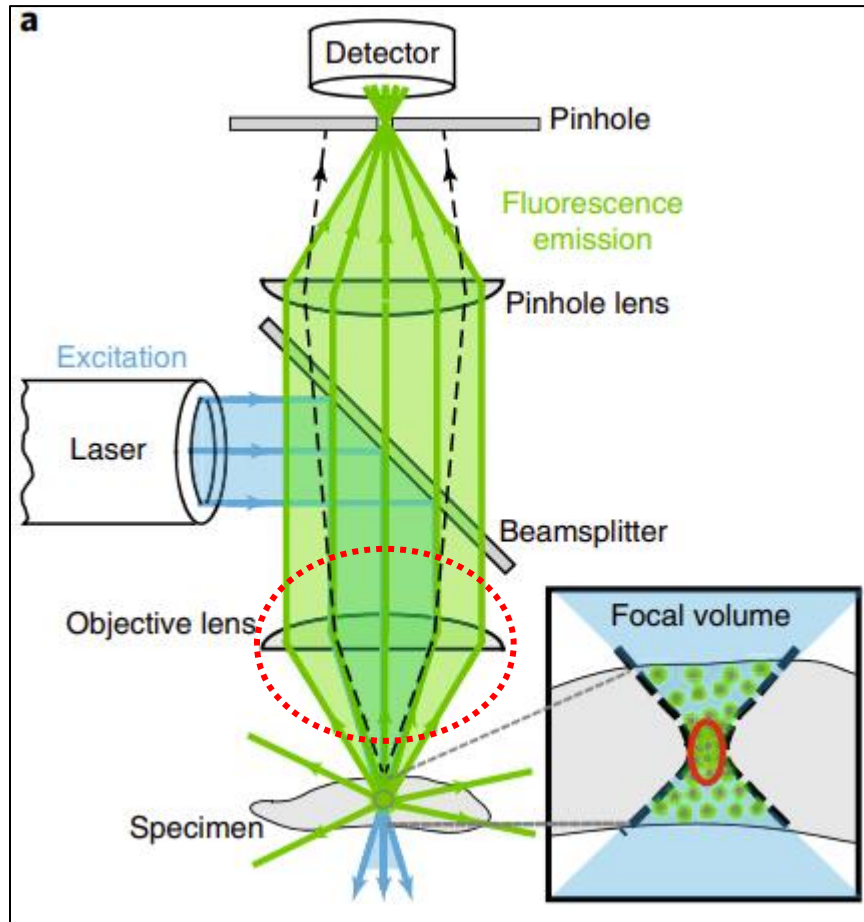

- When imaging deeper into the samples it is important to match the refractive index of the sample.
- Silicone, glycerol and water lenses outperform oil immersion lenses for thick biological samples.

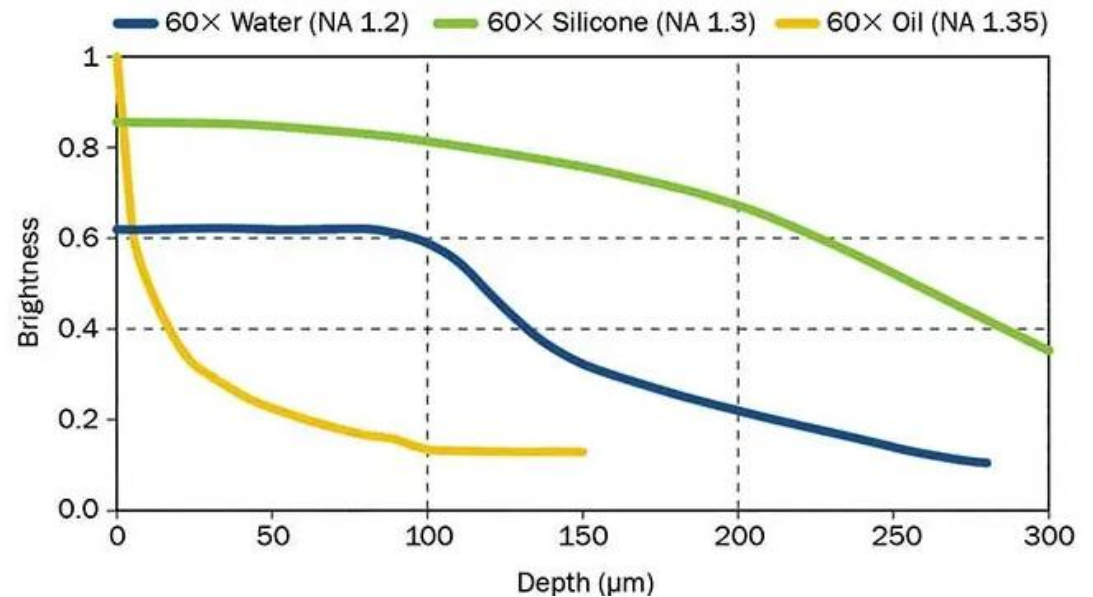

<https://evidentscientific.com/en/learn/white-papers/silicone-immersion-objectives-for-higher-resolution>

Point scanning Confocal – The Beamsplitter

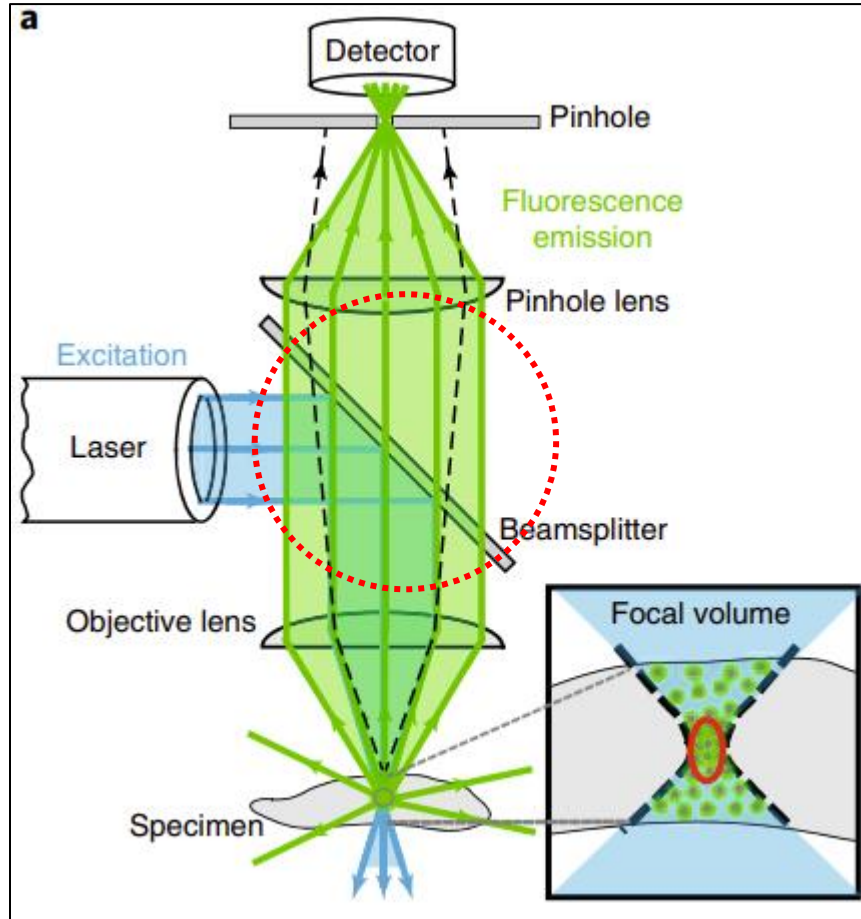

- Since we're using lasers with a specific wavelength an excitation filter is not necessary in the majority of cases.

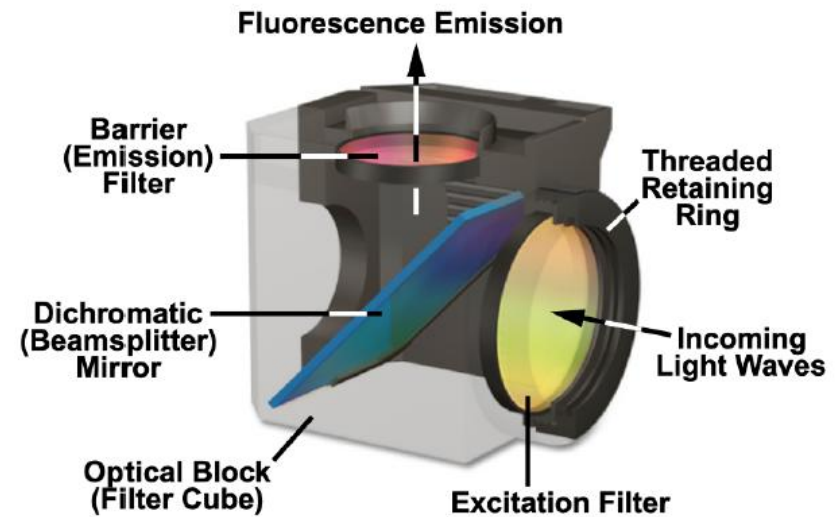

Point scanning Confocal – The pinhole

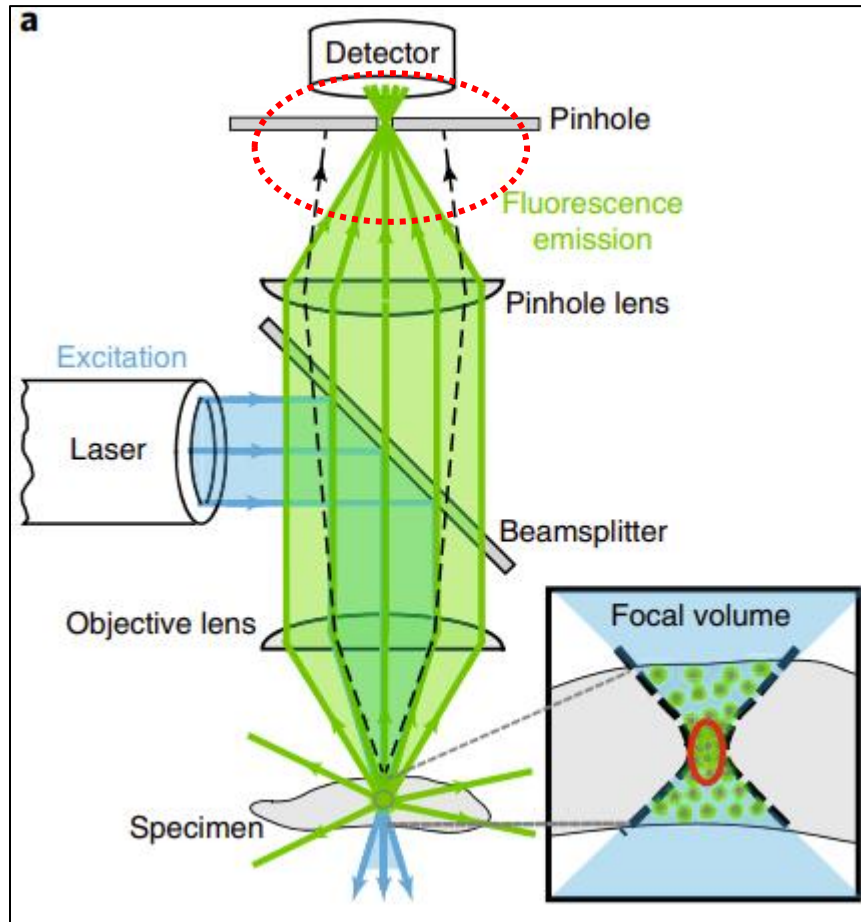

- The pinhole is placed in image plane which is a conjugate plane of the focal plane, **thus confocal**.
- **The pinhole rejects out of focus light.**

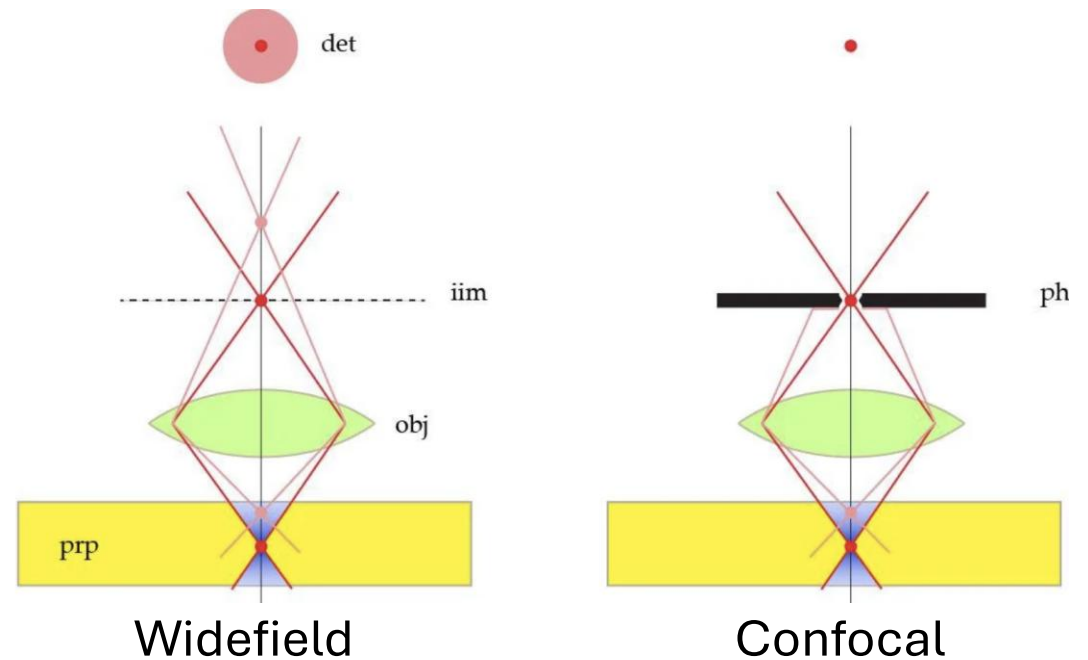

More on the pinhole

The point spread function (PSF) describes how a microscope blurs individual point emitters due to diffraction

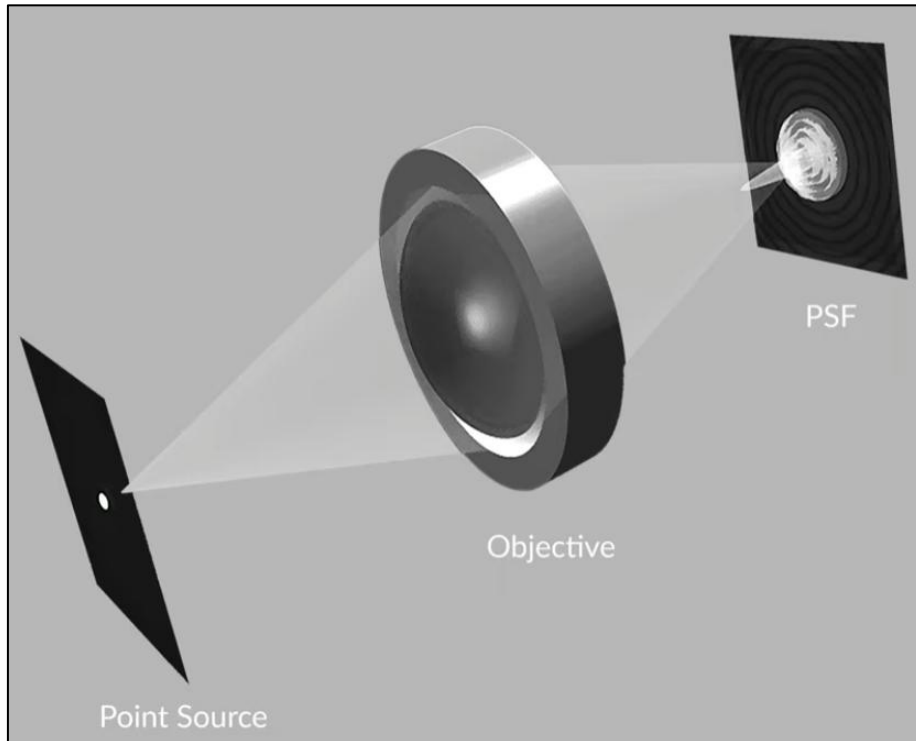

In an ideal system the PSF is an Airy pattern

The shape of this pattern depends on the numerical aperture (NA) of the objective and the wavelength.

More on the pinhole

With the pinhole we can control how much of the Airy pattern we allow to pass

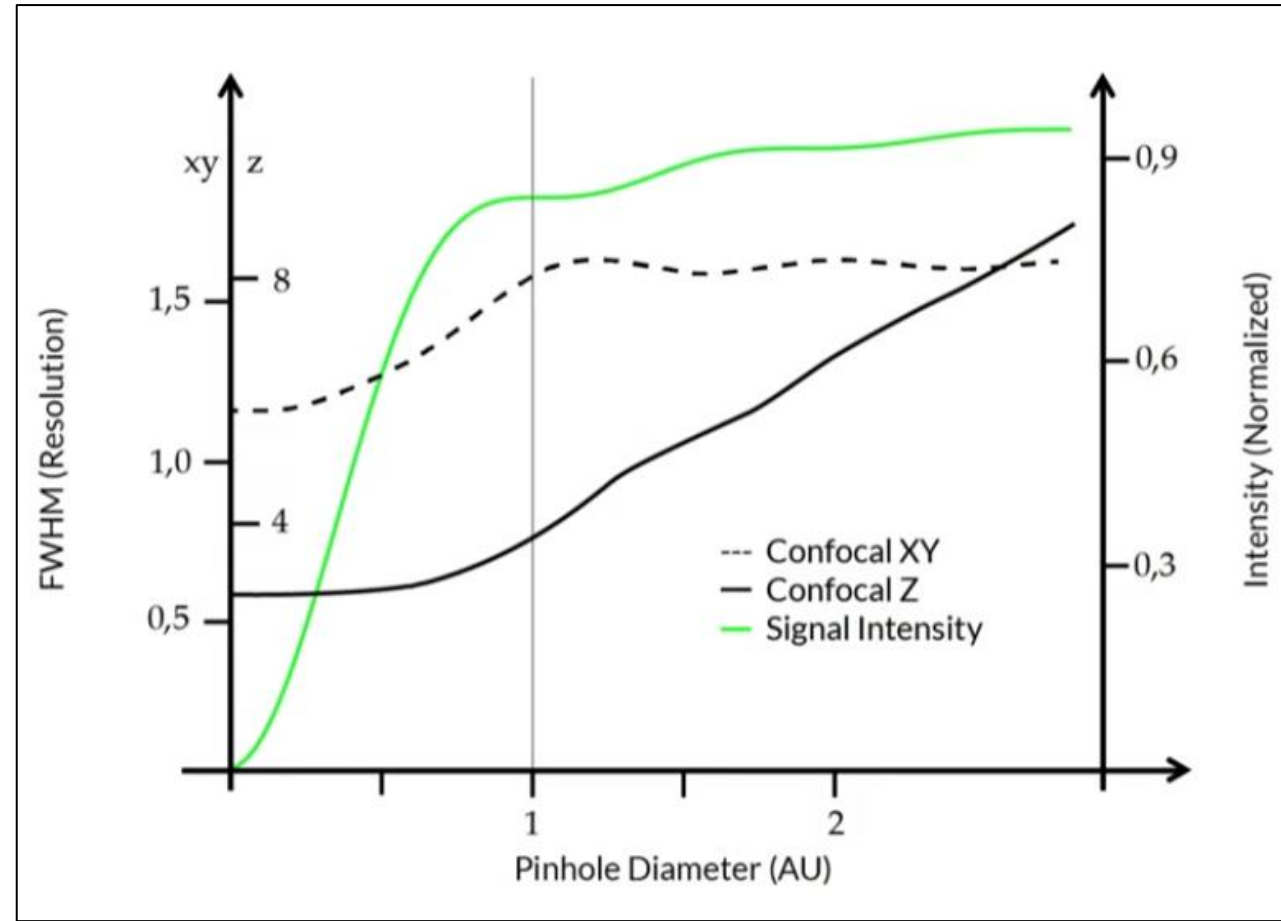
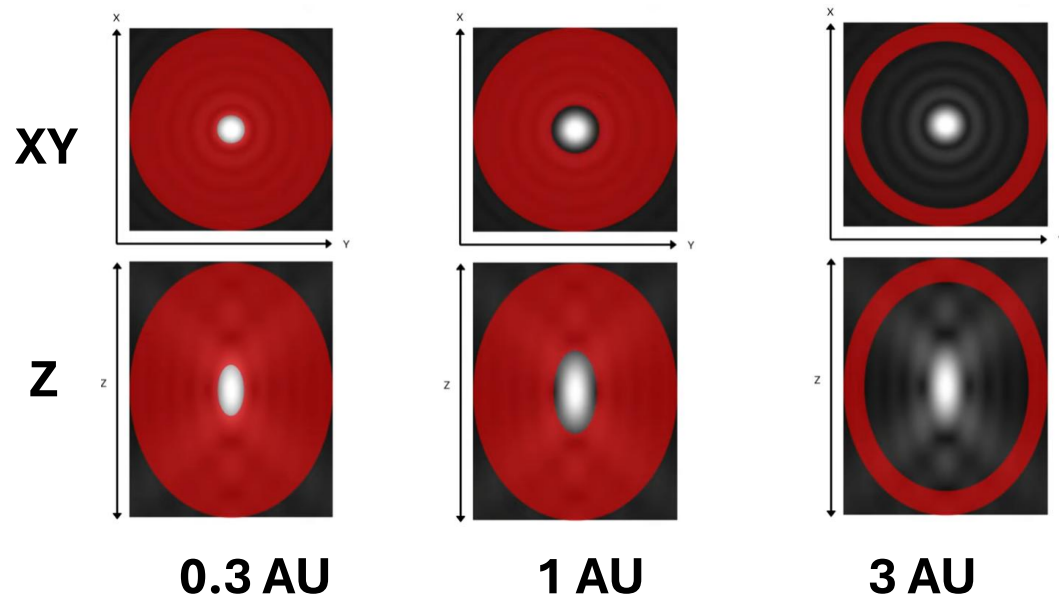

More on the pinhole

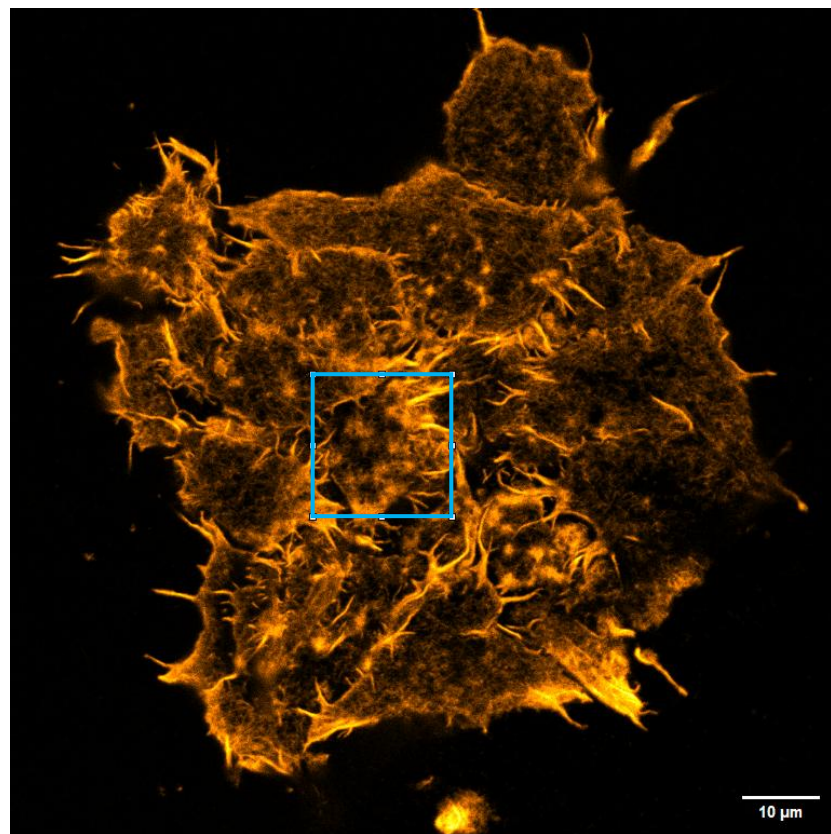

HEK cells stained with actin-stain green

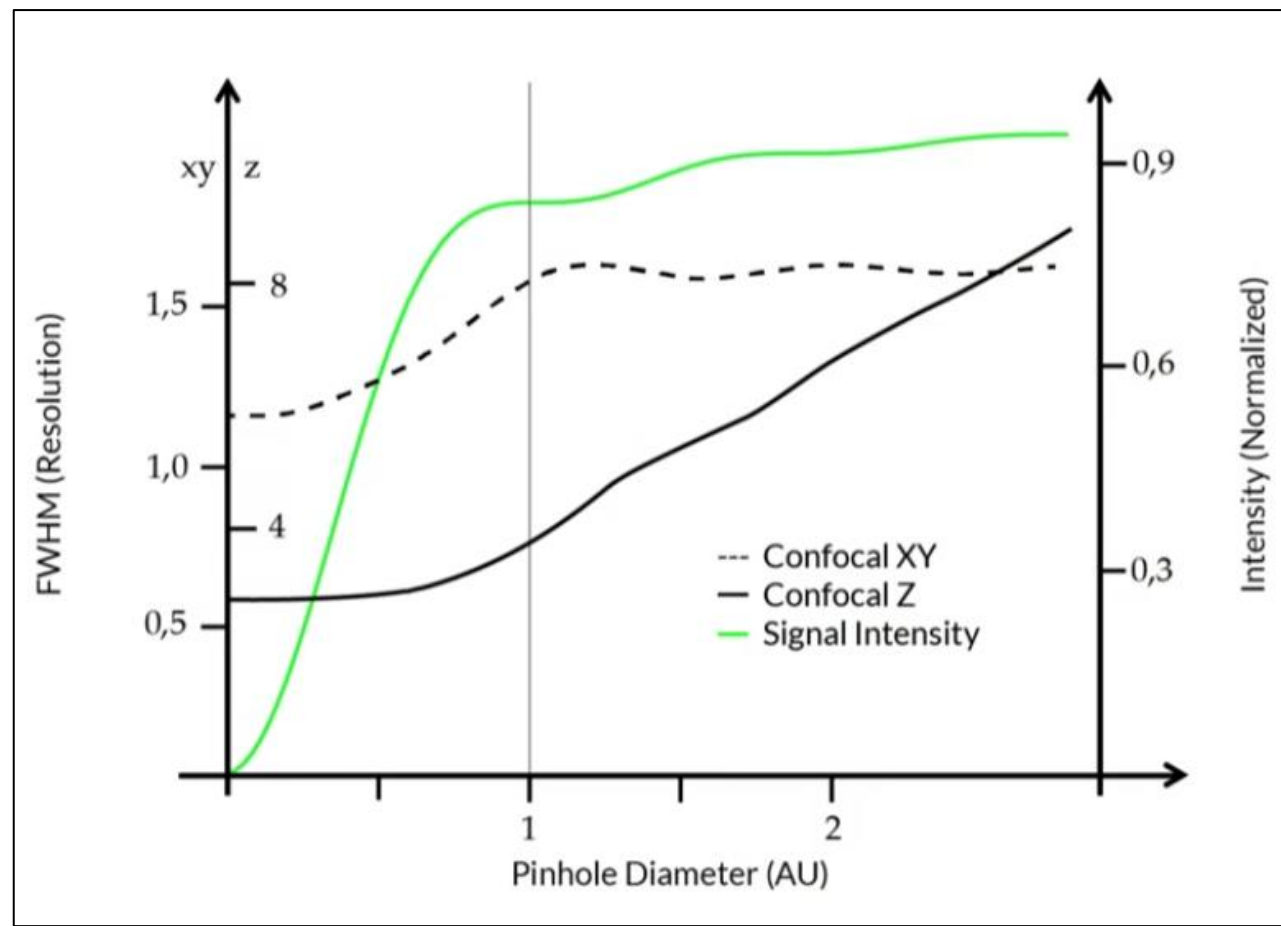

More on the pinhole

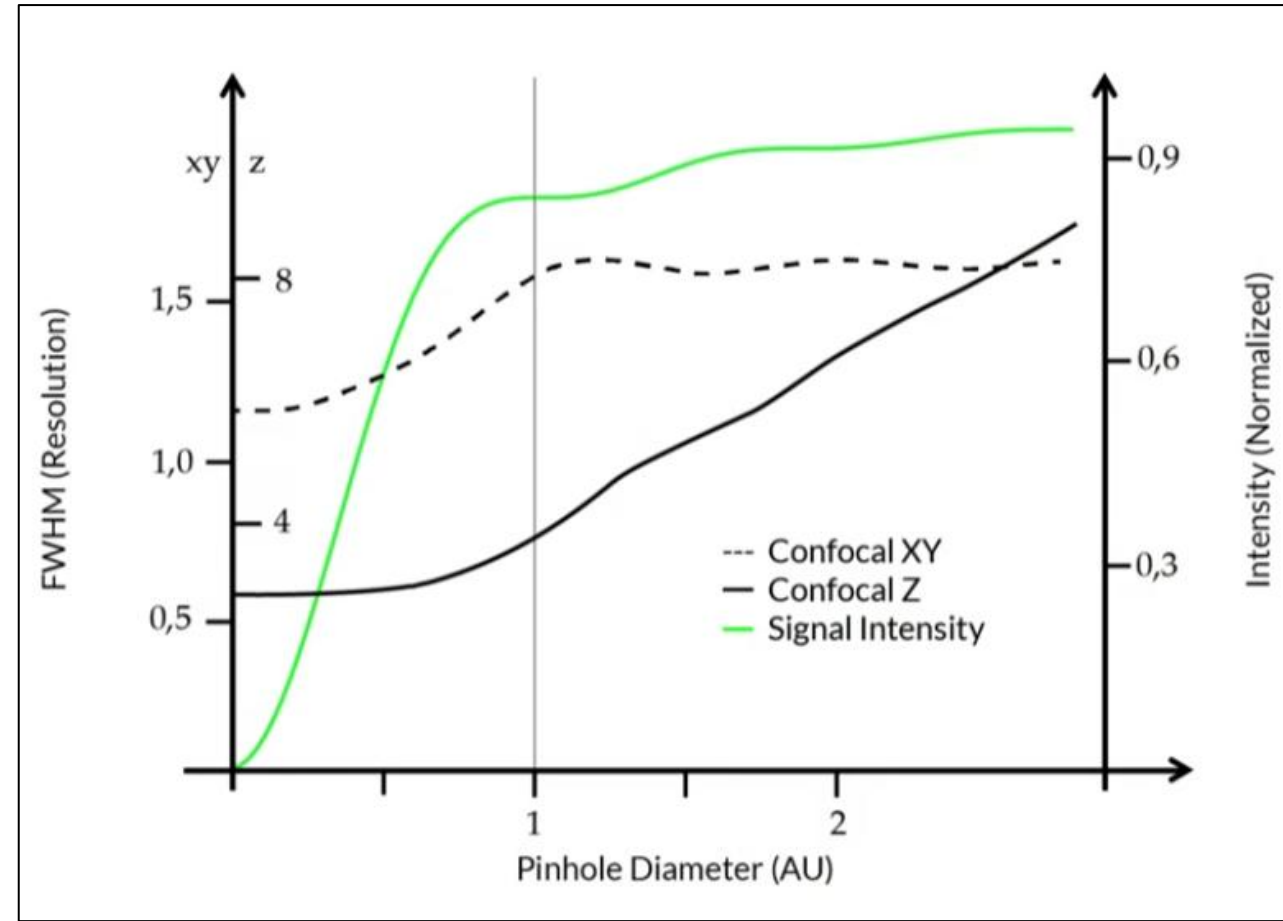
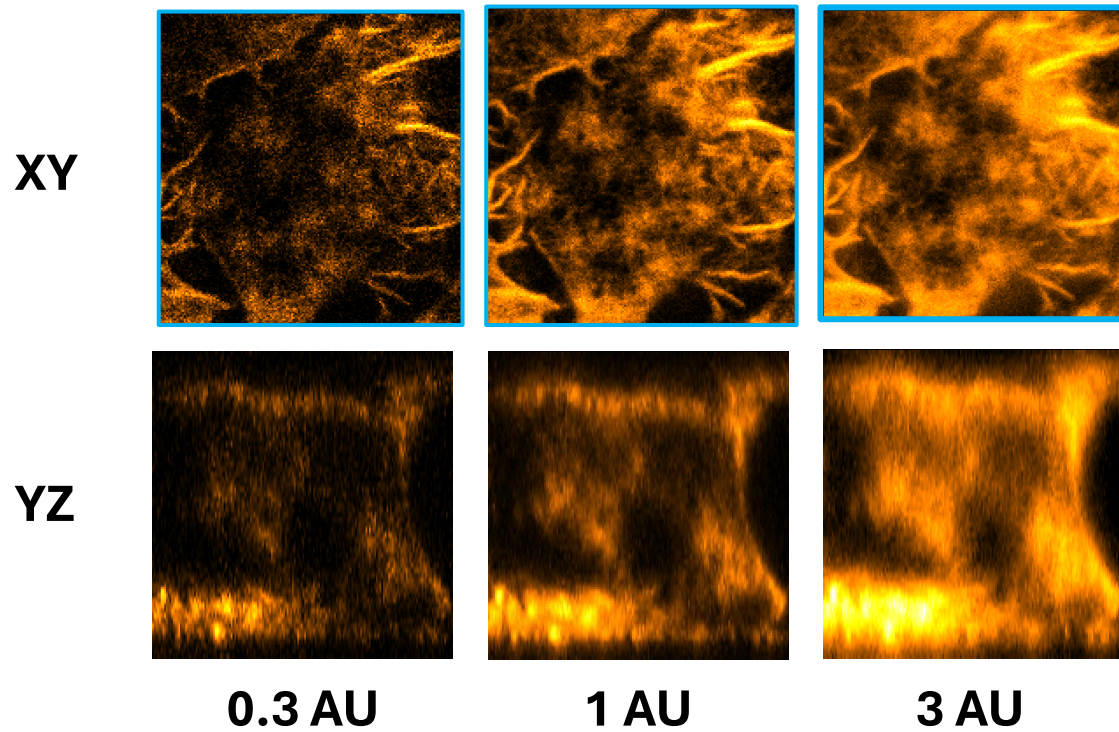

* The intensity range displayed is different for each image

More on the pinhole

There is an important decrease in intensity below 1AU

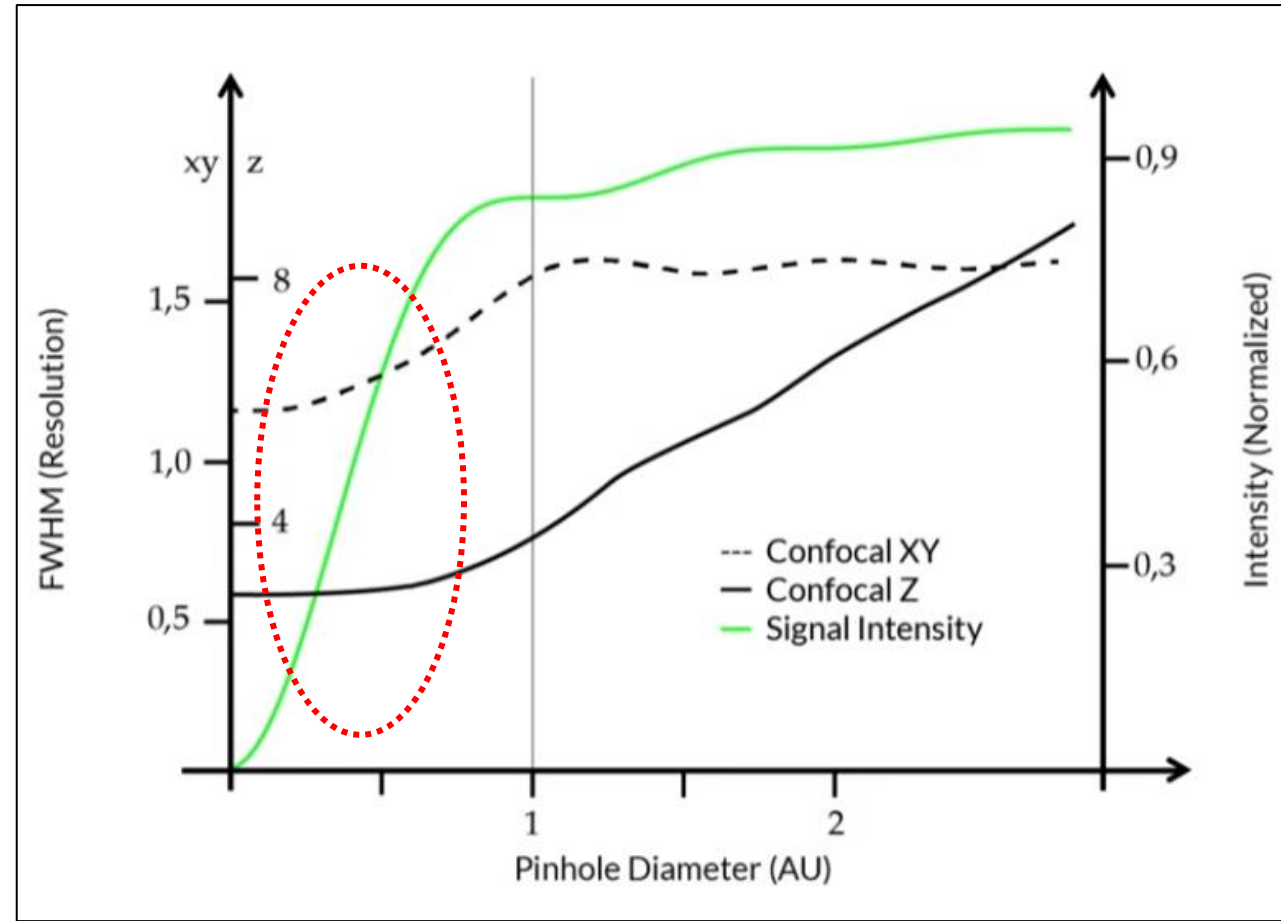
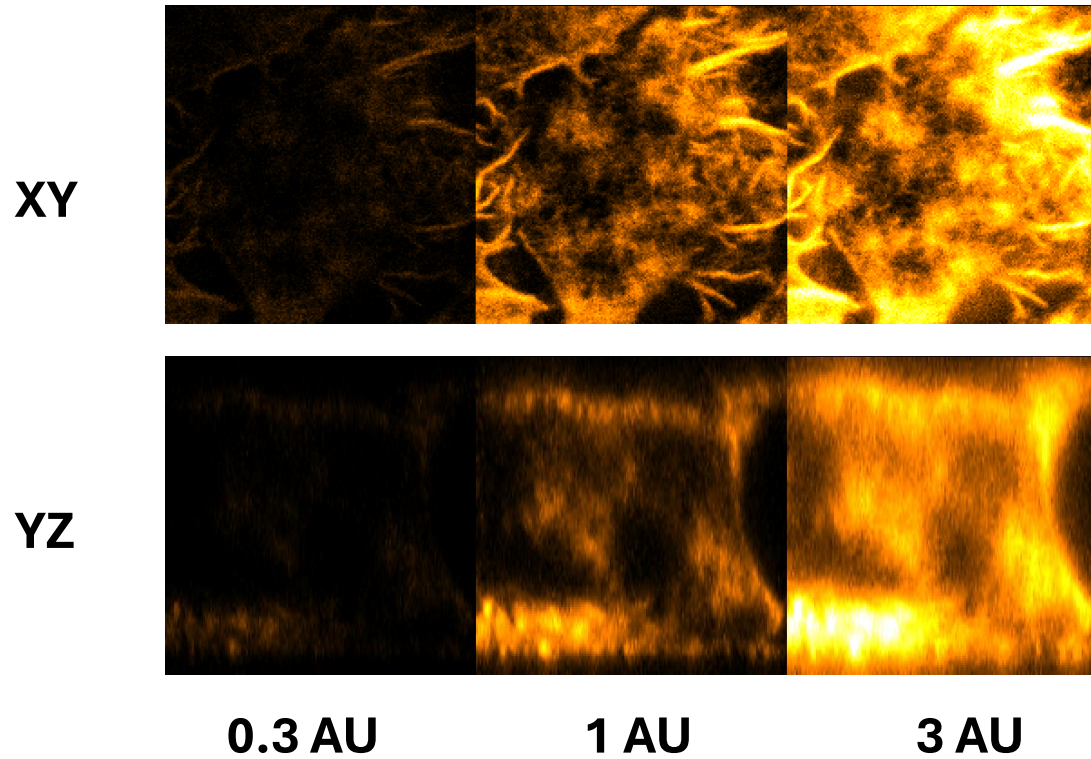

Emission Wavelength Selection

In some systems, diffraction gratings and prisms are used to separate the different emission wavelengths and direct them to multichannel or single detectors.

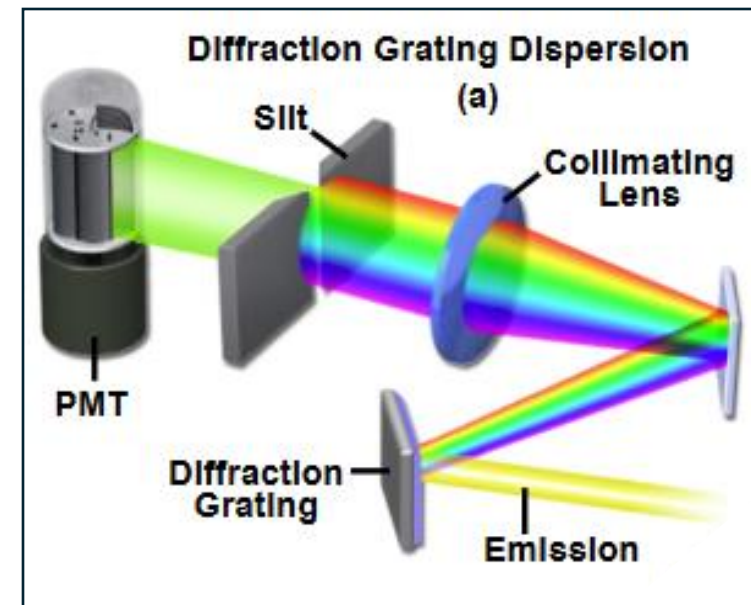
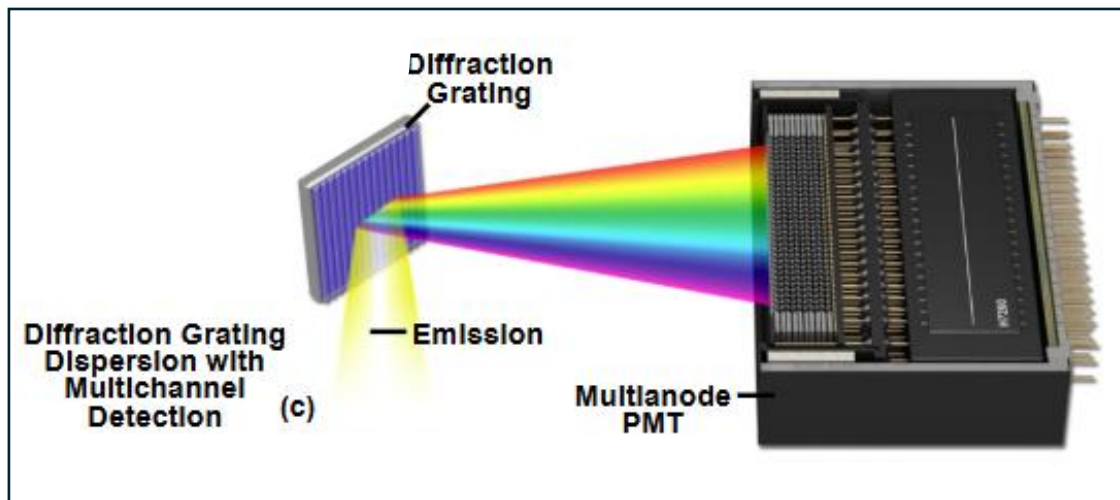

Point scanning Confocal – The detector

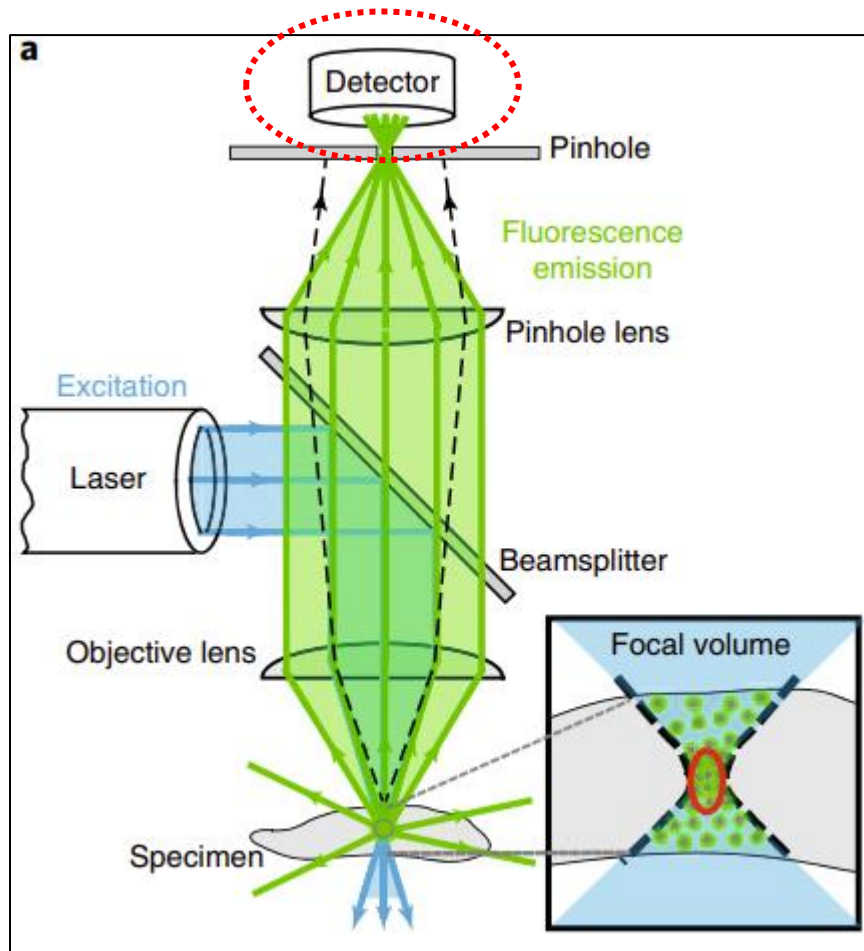

The photomultiplier

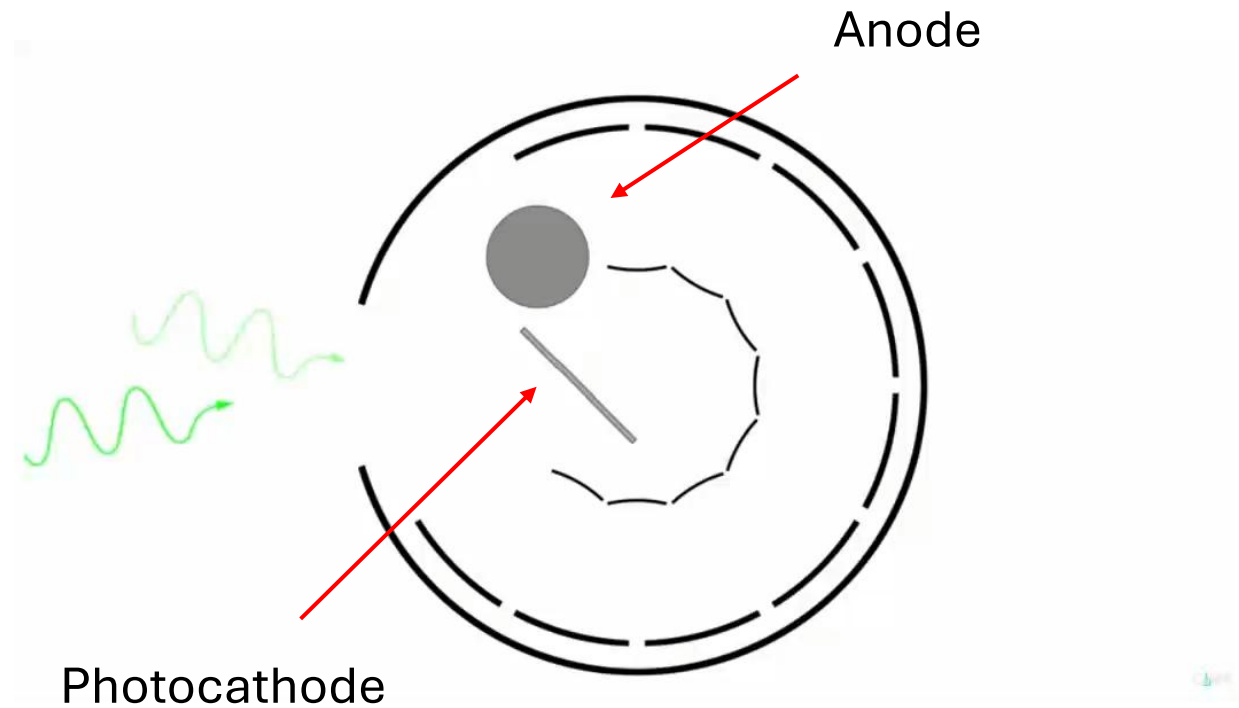

OiVM – Optical Imaging & Vital Microscopy
– Introduction to confocal Microscopy

More on Photomultipliers (PMT)

PMTs are fast but not very efficient, in alkali PMTs only 1 in 4 photons excites an electron (quantum efficiency of 25%).

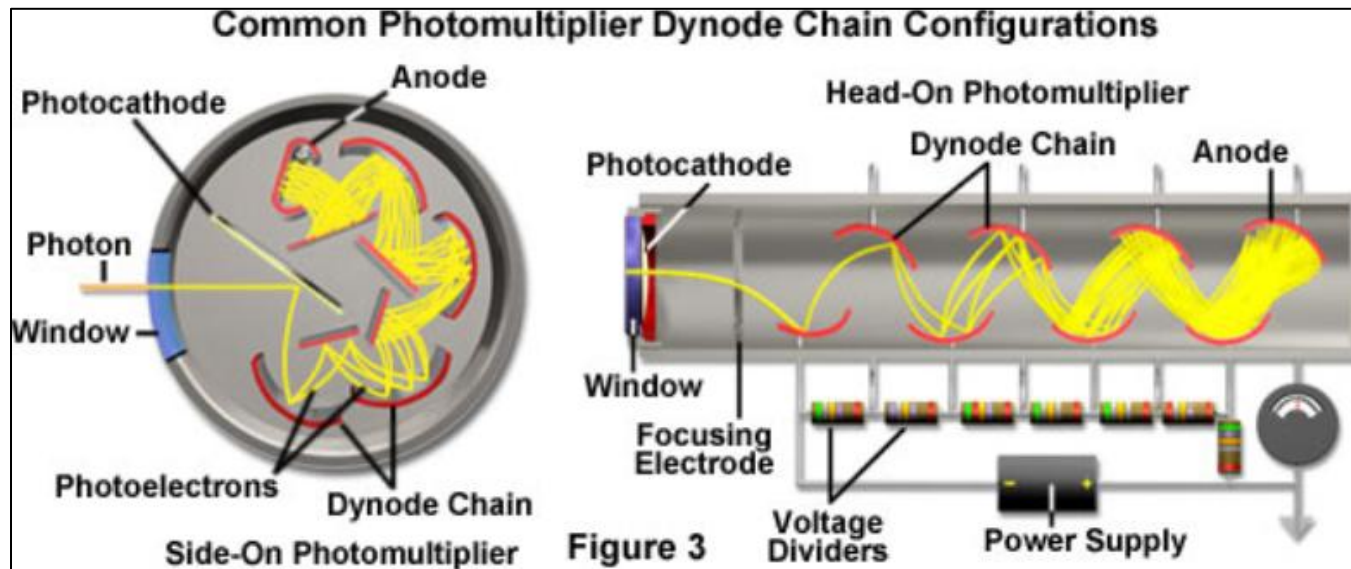

The **voltage between the cathode and the anode** increases the production of electrons and amplify the signal – this is controlled through the **gain** in the confocal software.

More on Photomultipliers - GaAsP detectors

Gallium Arsenide Phosphide have a higher sensitivity than traditional multi-Alkali PMTs, having a higher quantum efficiency.

The coating of the photocathode is made of Gallium Arsenide Phosphide

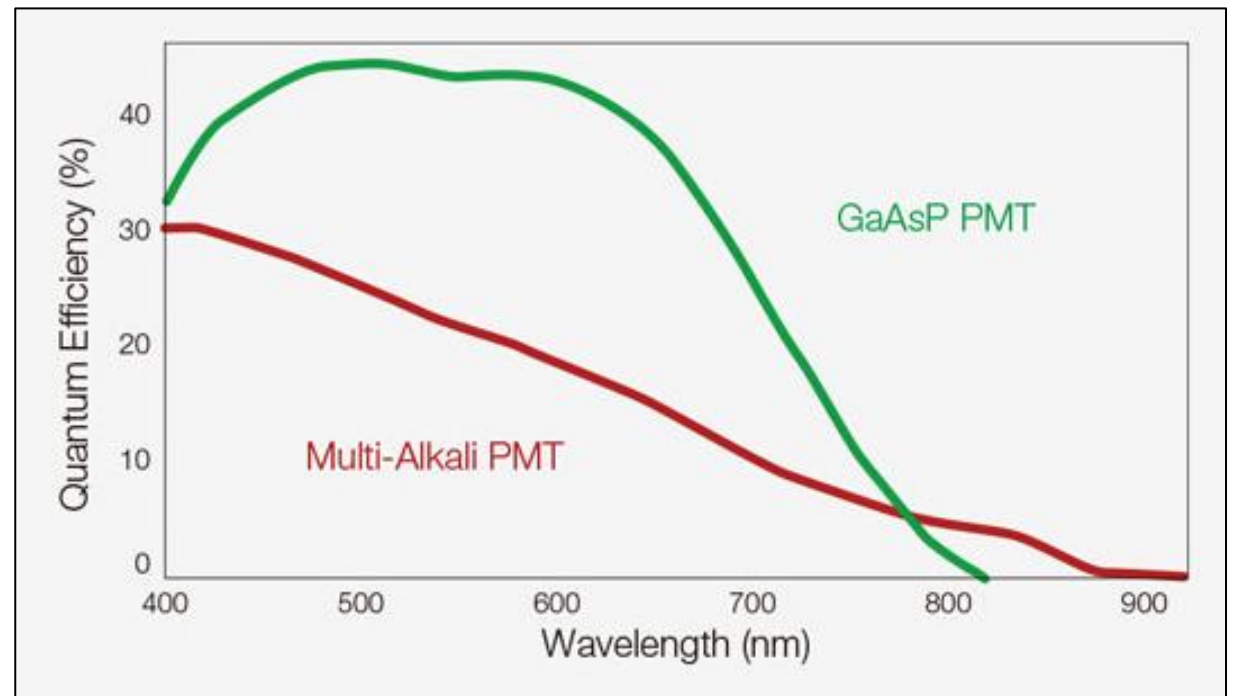

Other detectors – Avalanche Photodiodes (APD)

APDs have high signal to noise ratio and a wide dynamic range simultaneously. Making easier to image samples with a mixture of dim and bright features

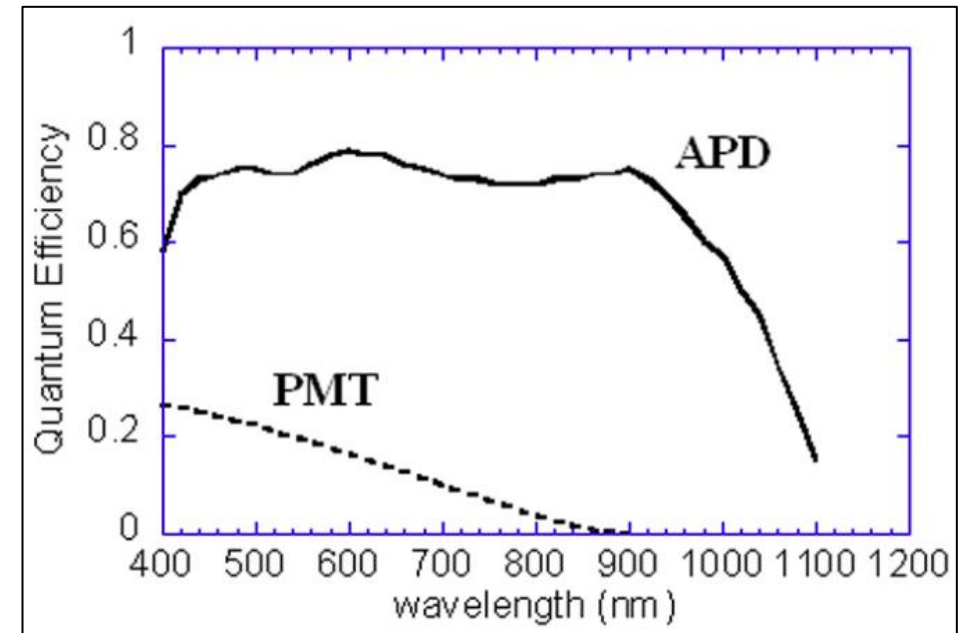
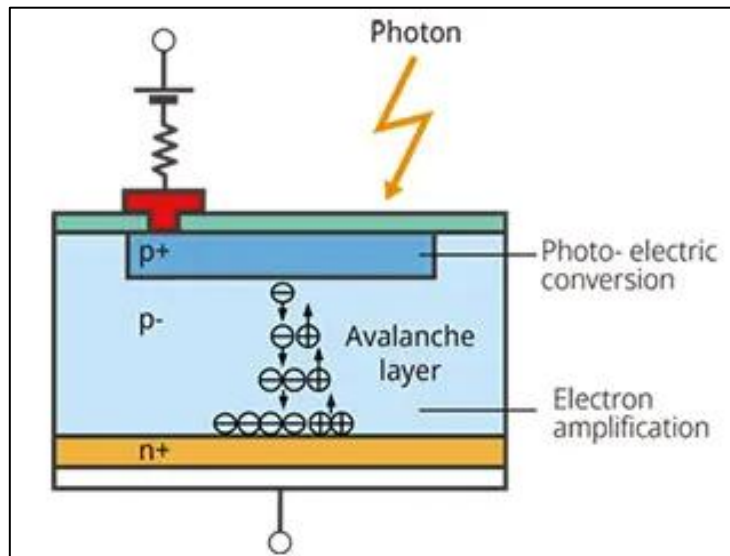

W. Lawrence & P. Wallace et al. 2009

Other detectors – SiVIR

The SiVIR detector is a silicon APD with a high sensitivity - allowing efficient detection even with the short dwell times of resonant scanning.

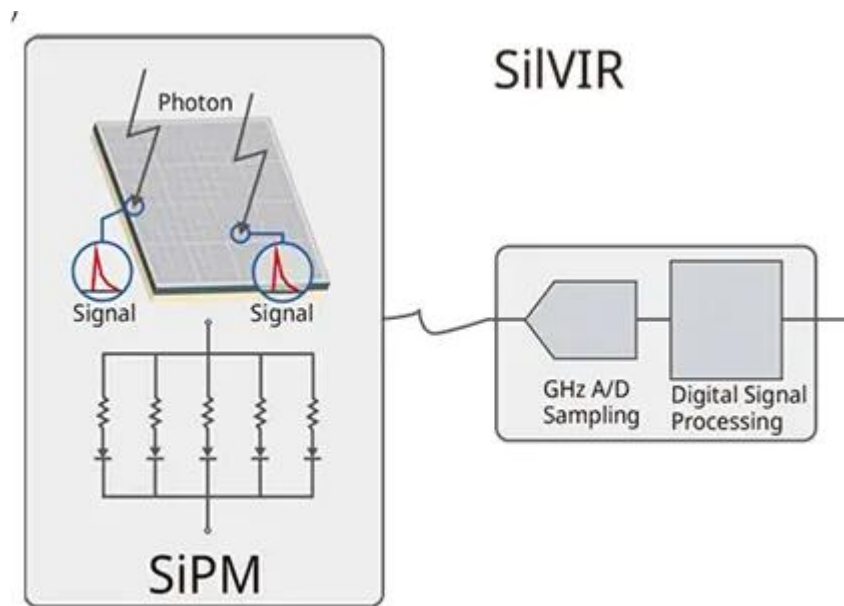

Hybrid detectors

Hybrid detectors combine of the photomultiplier tube with a solid-state avalanche photodiode.

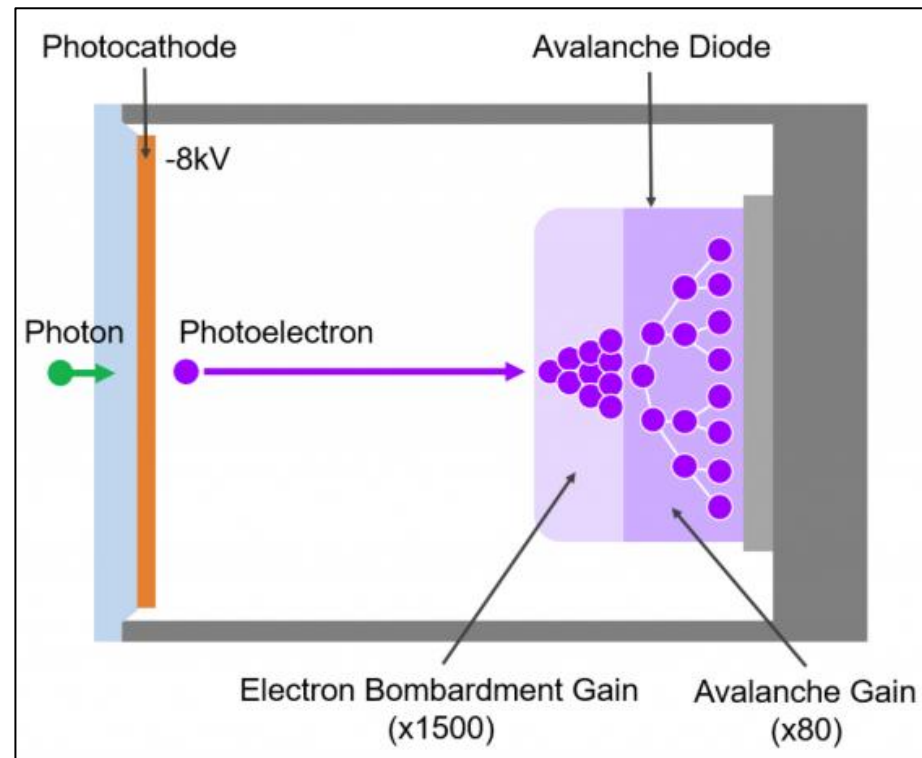

The Result

The optical sectioning capabilities of the confocal allow us to take high contrast images that can be used to produce 3D models.

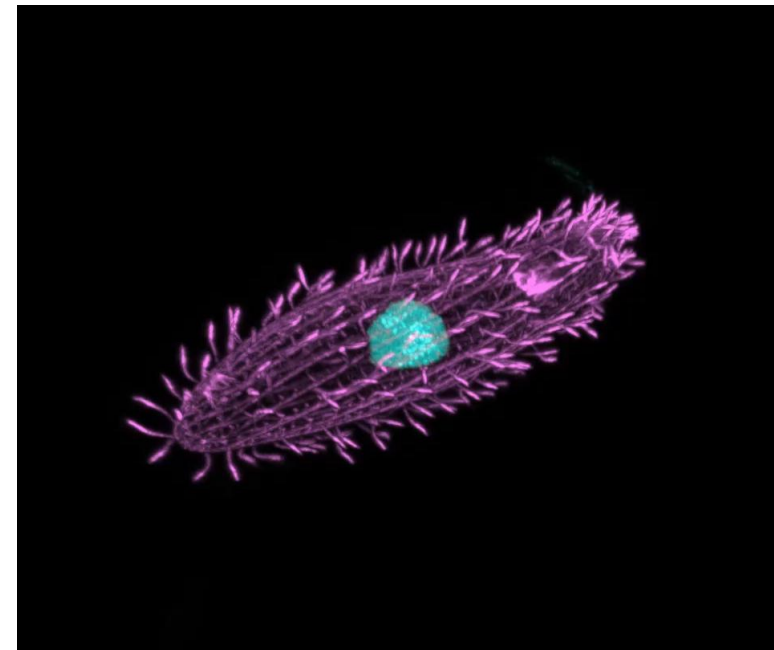
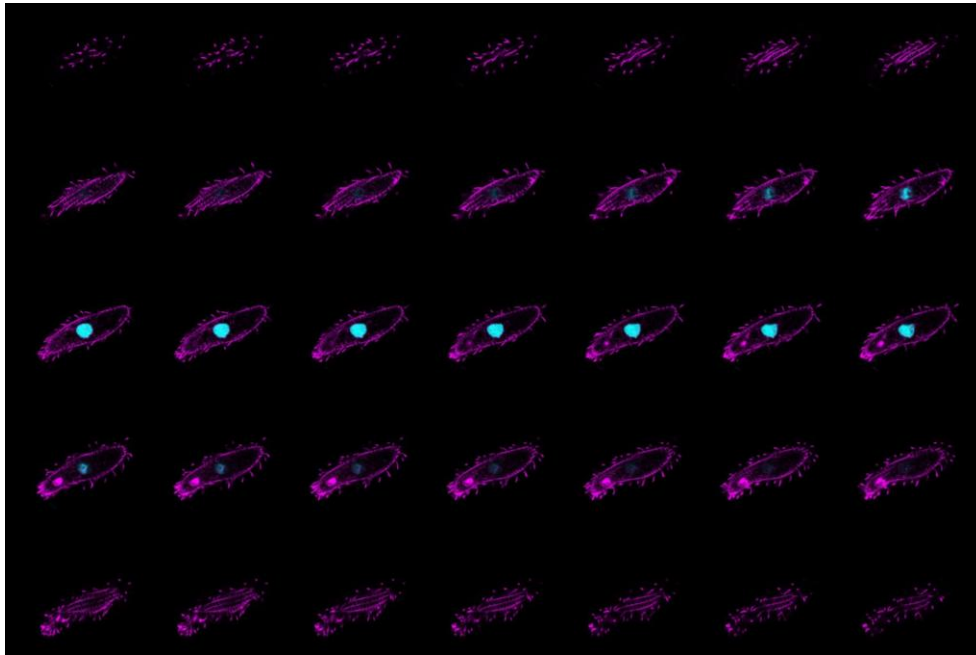

Tetrahymena stained with Dapi and AF594 Tubulin

Ribbon Scanning Confocal

Ribbon scanning was developed to image efficiently large samples at high resolution.

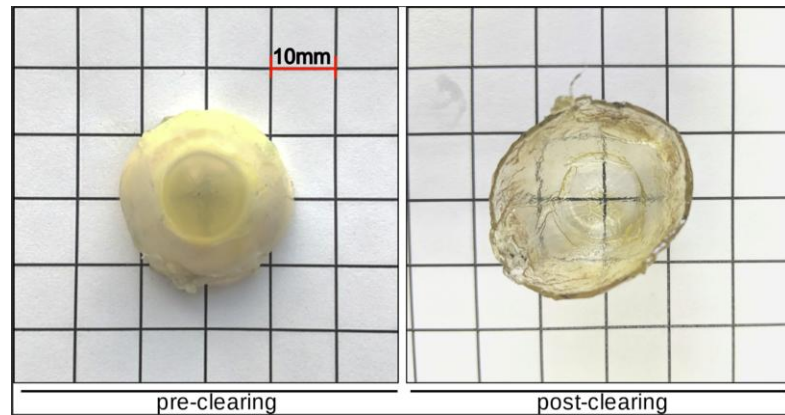

Human eye

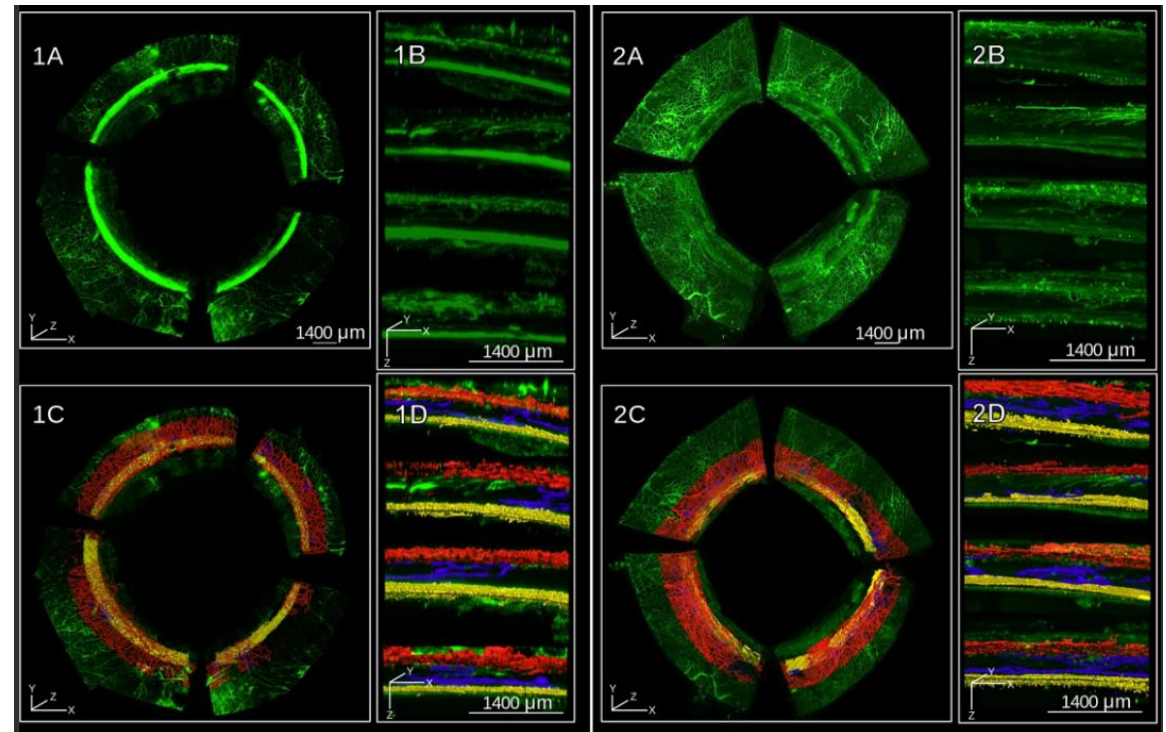

Ribbon Scanning Confocal

Ribbon scanning uses a continuous stage movement synchronized with a high-speed resonant scanner to acquire data in long, seamless vertical "strips" or ribbons.

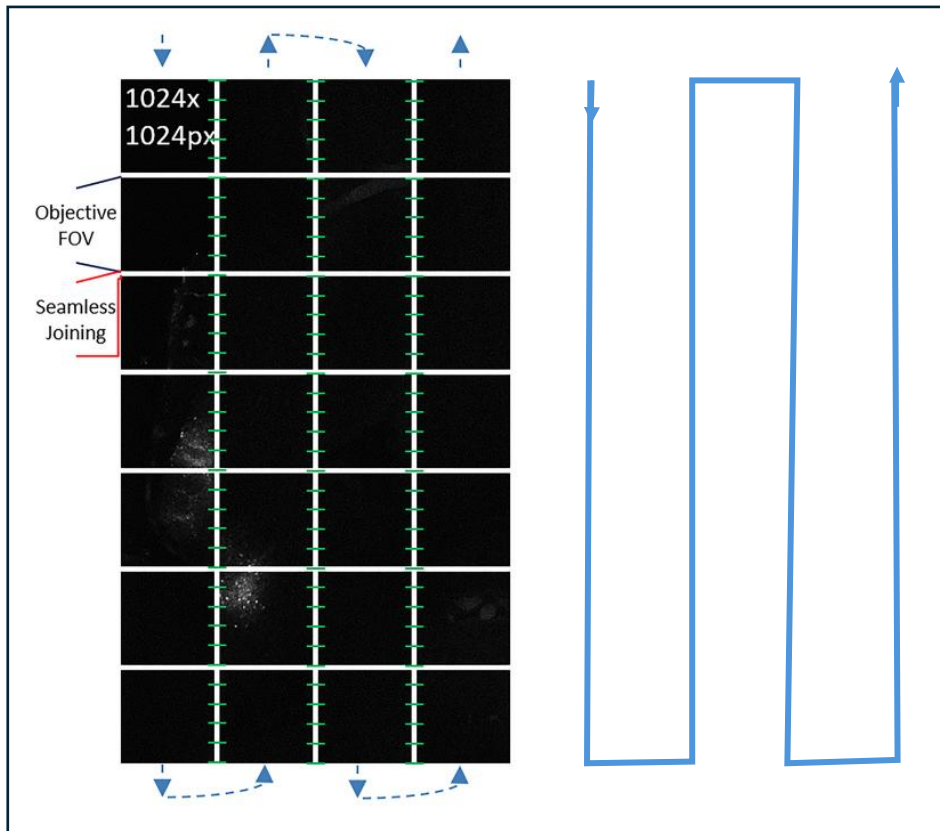

To obtain high resolution at low magnification, the objectives in this system are larger to increase the numerical aperture and extend the working distance

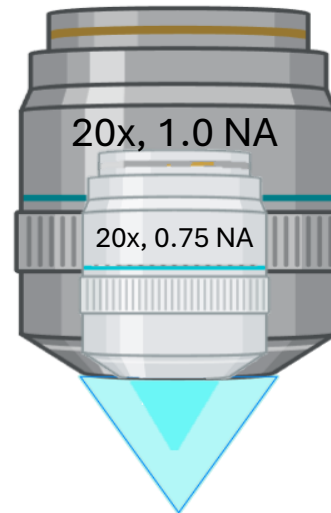

Spinning Disk Confocal Microscopy

If instead of a single pinhole we use many of them, images can be obtained faster.

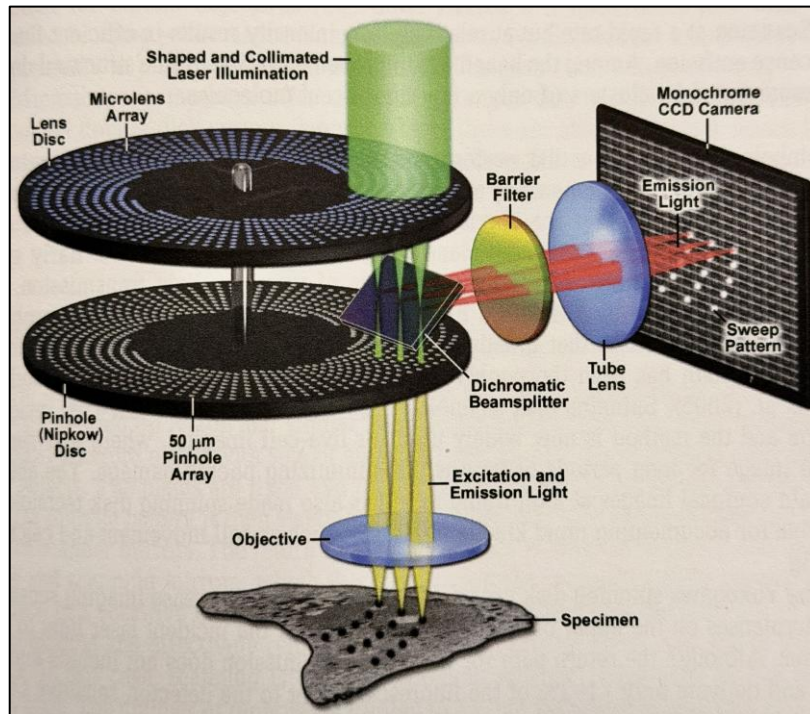

Ideal for live-cell imaging

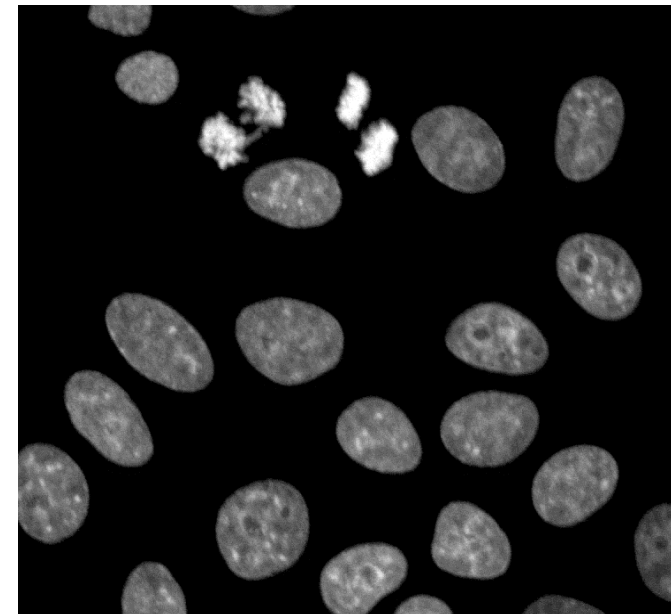

Spinning Disk Confocal Microscopy

This technique uses lower laser power, making it gentler and better suited for live-cell imaging.

The pinhole size is usually optimized for high magnification lenses.

The faster acquisition is not free

- The pinhole size is not dynamic as in point scanning confocal.
- The close proximity and size of the pinholes gives rise to crosstalk, reducing the out of focus light rejection.

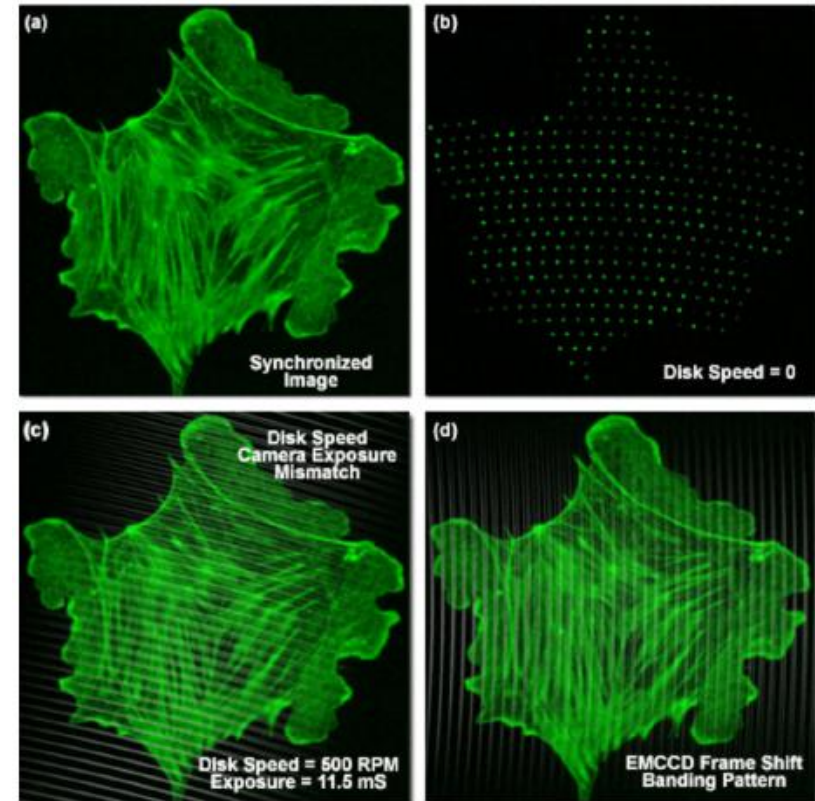

Line Scanning Confocal Microscopy

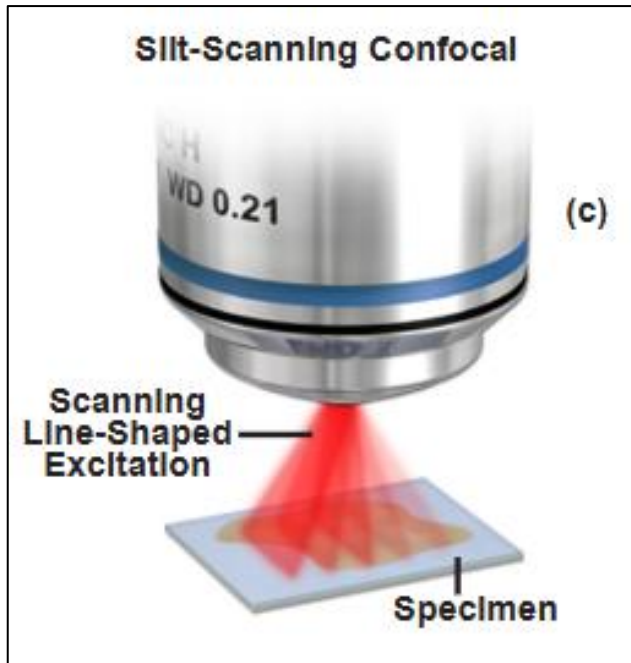

Line-scan confocal trades out of focus light rejection for higher imaging speed.

Line-scanning confocal uses a slit (physical or virtual via rolling-shutter/line detector) as the confocal aperture to reject out-of-focus light along one dimension.

Some implementations use a linear detector array or synchronized camera shutter instead of a physical slit.

Image scanning Microscopy

Combining the confocal microscope configuration with an array of detectors instead of a single detector

- Airyscan (Zeiss)
- NSPARC (Nikon)
- MATRIX (Abberior)

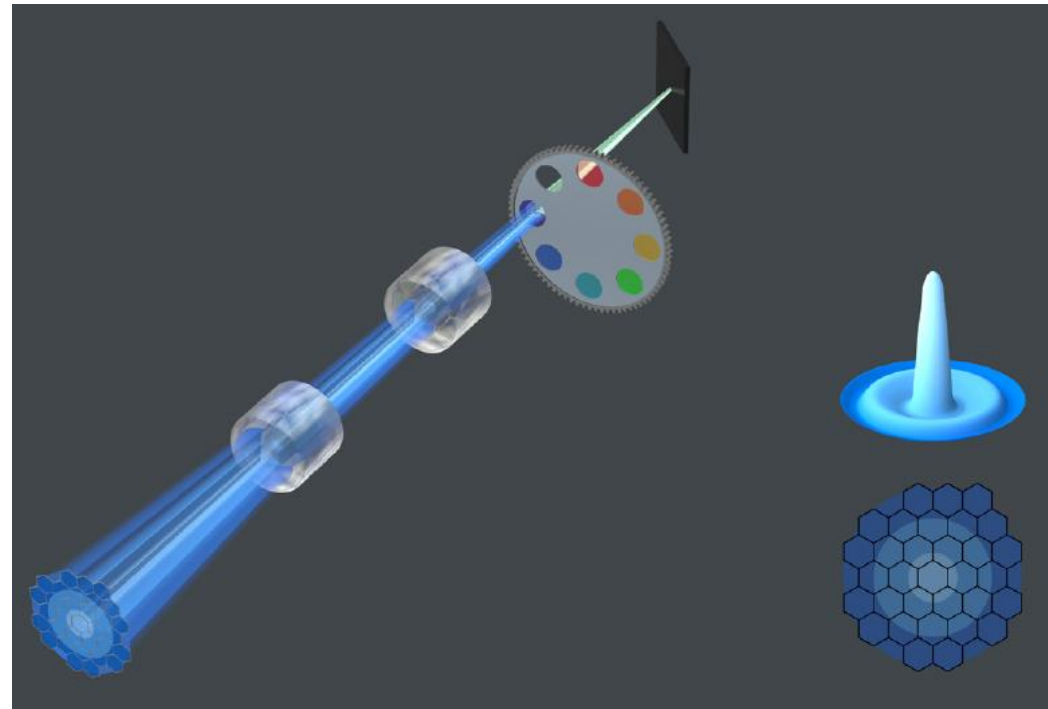
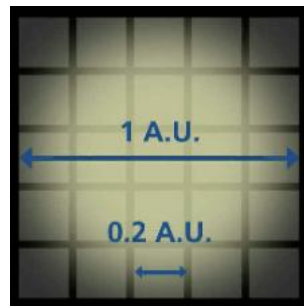
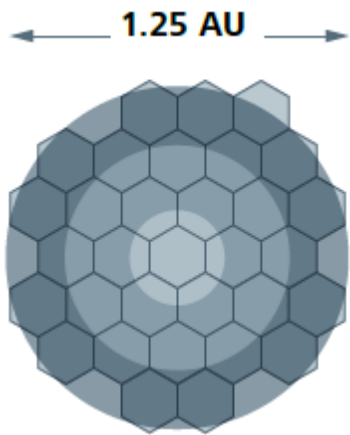

Image scanning Microscopy

Combining the confocal microscope configuration with an array of detectors instead of a single detector

- Airyscan (Zeiss)
- NSPARC (Nikon)
- MATRIX (Abberior)

These can be described as enhanced resolution confocal techniques

These resolution can be achieved closing the pinhole if your detector is sensitive enough (Leica, Evident/Olympus)

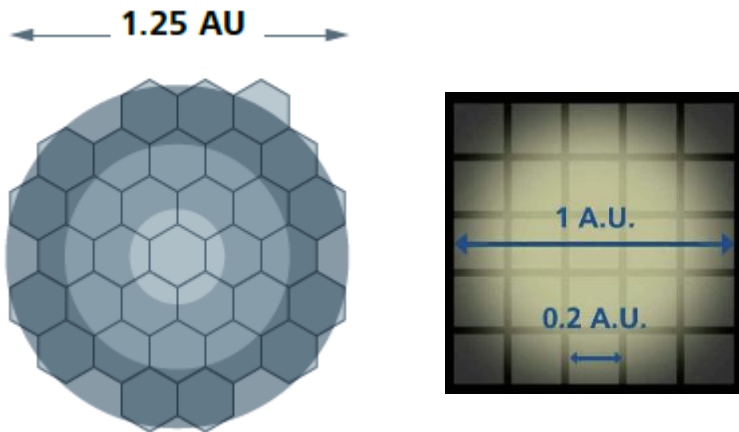

Re-scan Confocal Microscopy

- A second set of scanners re-scans the light at the pinhole plane into the emCCD detector.
- The second set of scanners sweeps over twice the angle range, magnifying the image over the sensor.
- The resulting image has a higher resolution

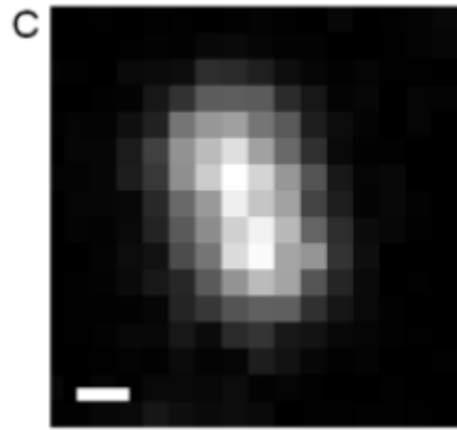

Confocal

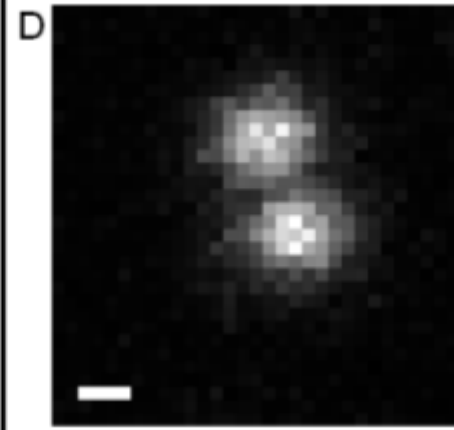

Re-scan
Confocal

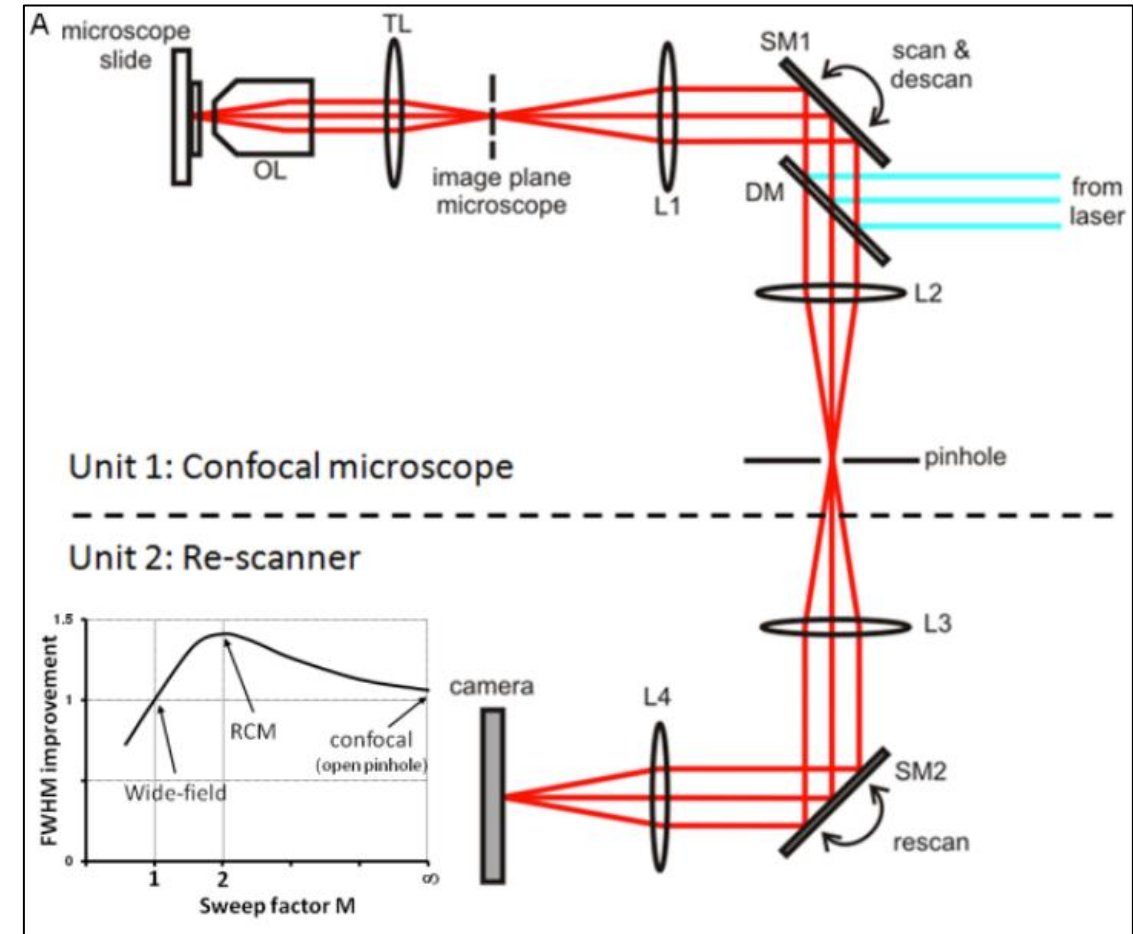

Widefield Deconvolution Microscopy

Knowledge of the Point Spread Function (PSF) of the system allow us to perform an operation called deconvolution

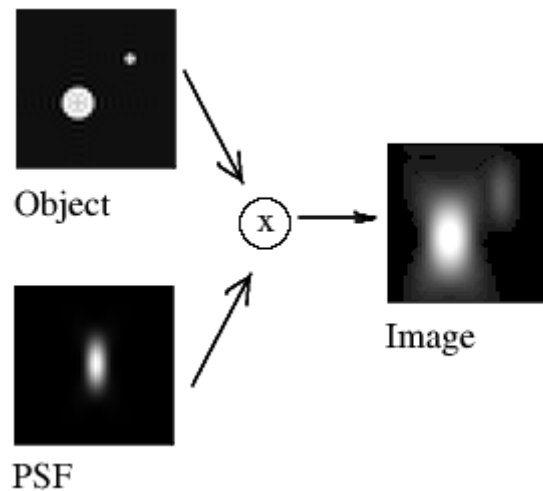

The aim of deconvolution is to find the true object image using knowledge of the PSF and the acquired image.

This process reassigns the out of focus light to the correct focal plane, increasing SNR and resolution.

Widefield Deconvolution Microscopy

Taking a Z-stack in a widefield microscope we can apply deconvolution and improve the contrast in the image

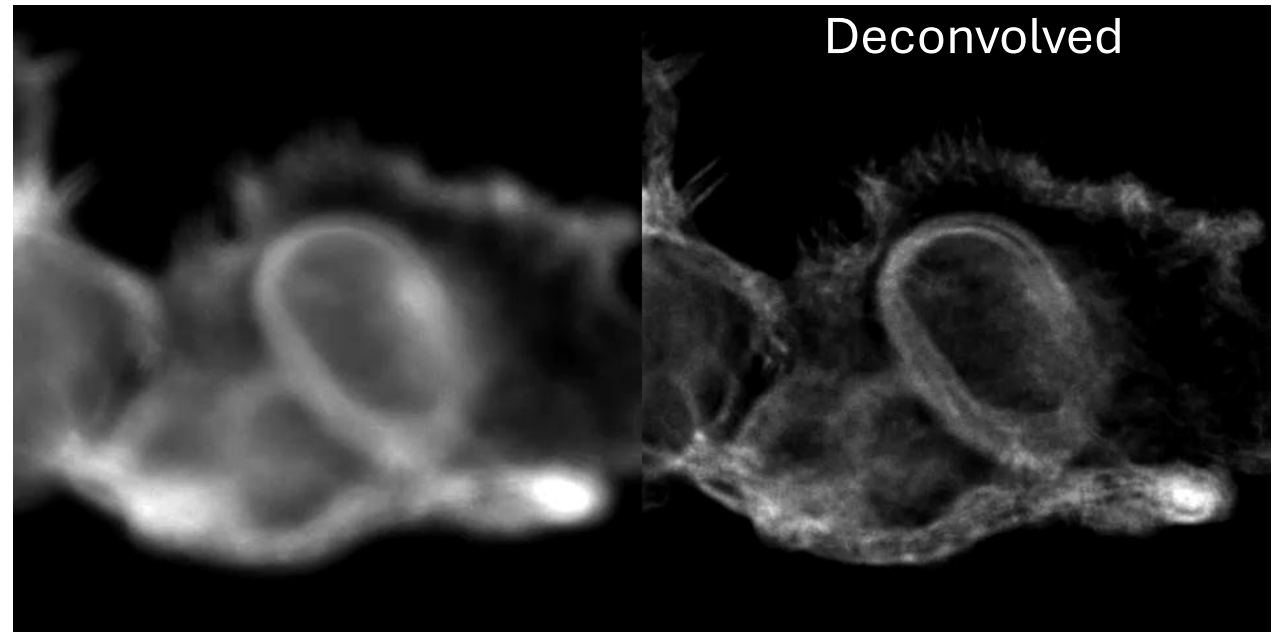
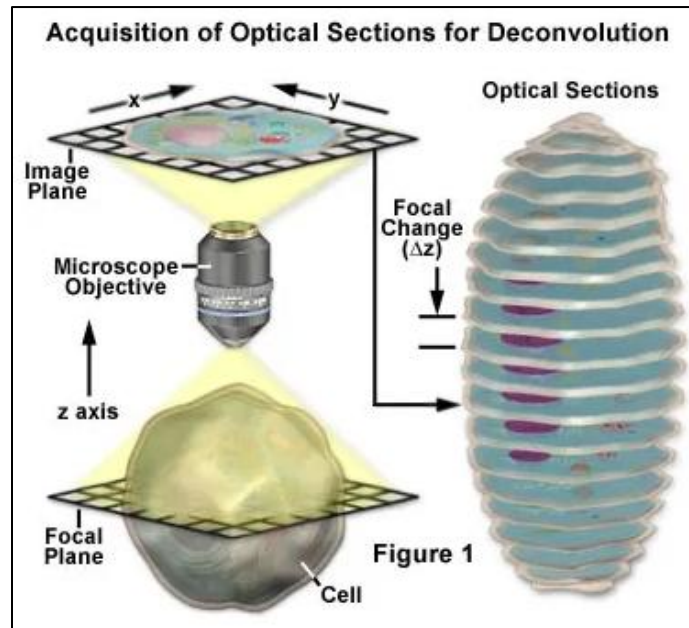

Deconvolution Microscopy

Taking a Z-stack in a widefield microscope we can apply deconvolution and improve the contrast in the image.

You can apply deconvolution to images obtained with other techniques including confocal microscopy.

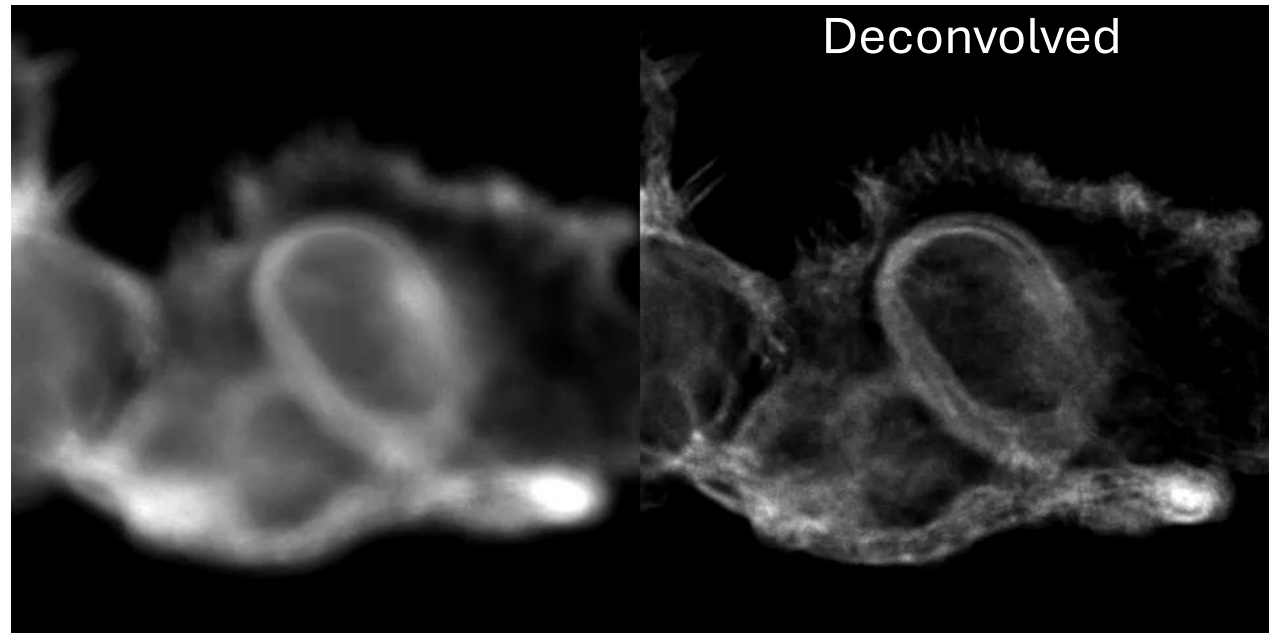

Practical considerations during a confocal experiment

The right sensor for the right wavelength

Different detectors will have different performance across the spectrum

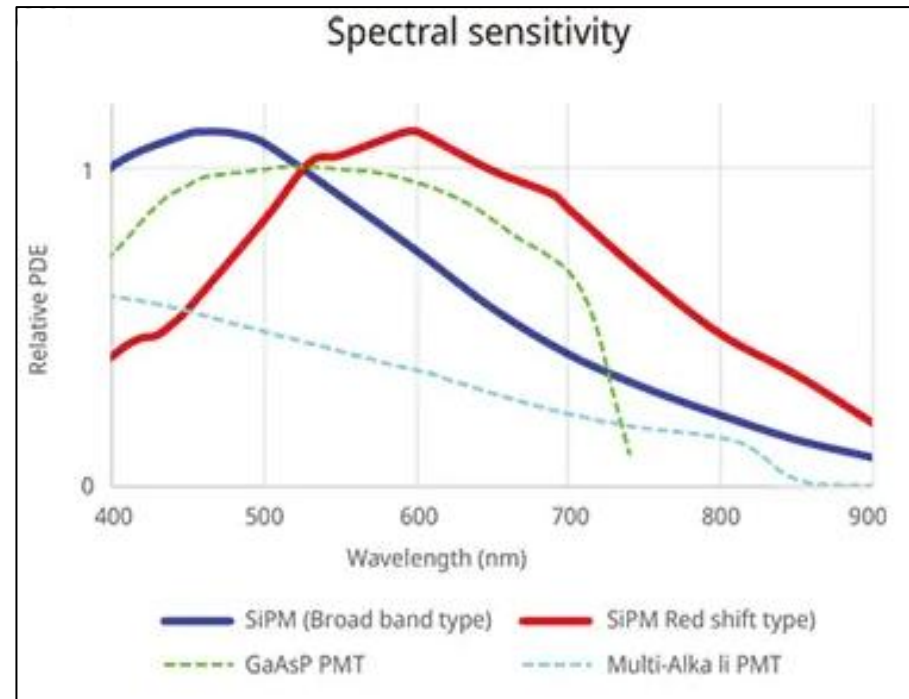
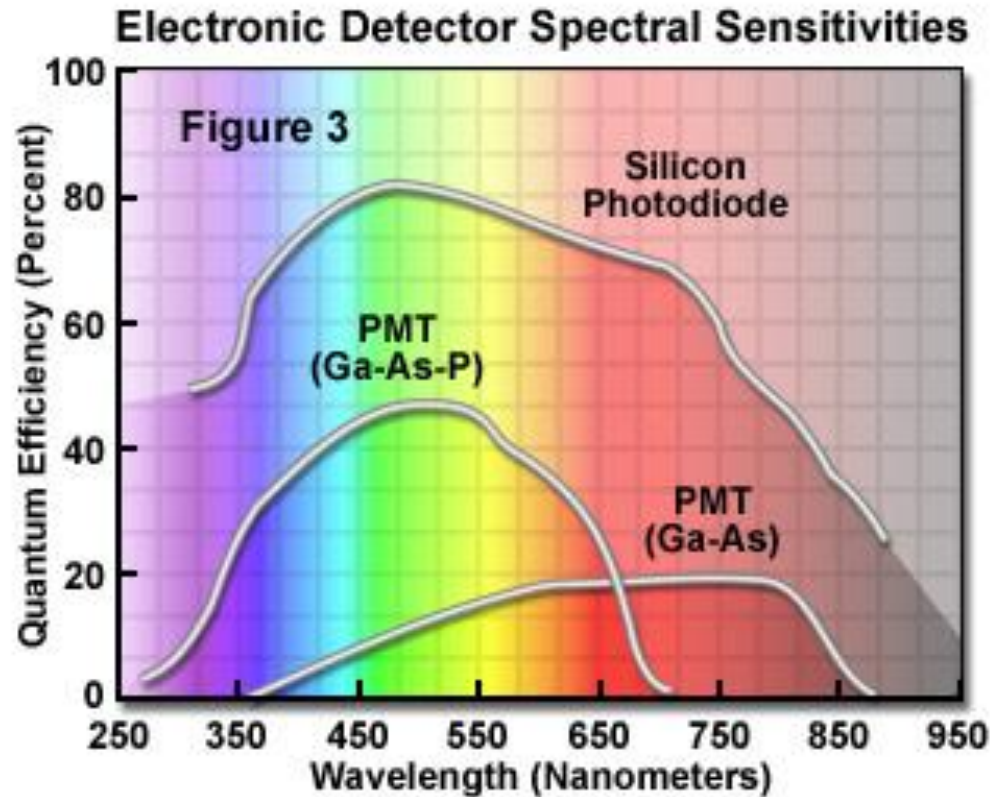

The right sampling

To ensure capturing all the spatial information available we must sample at least 2.3 times the smallest possible feature - Nyquist sampling.

Imagine two particles close together, to capture each we must sample (adjust pixel size) so that we can capture them.

XY pixel size is defined by the frame size (512, 1024, 2048) and by the zoom factor.

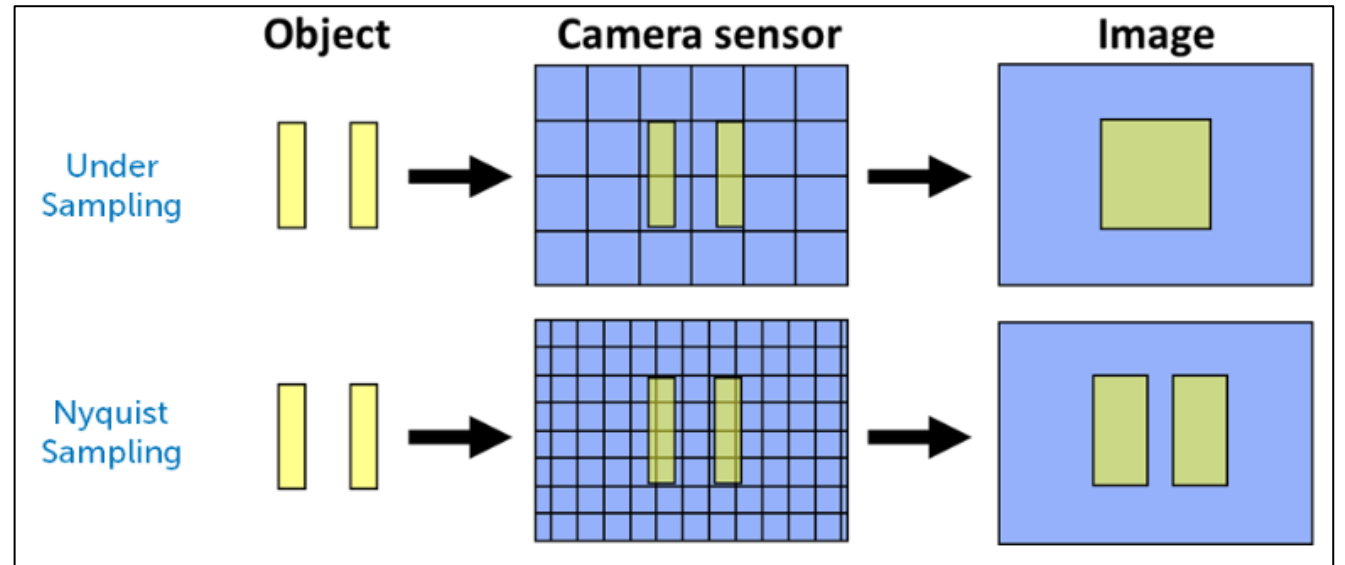

Adjusting the gain and offset

Gain (Actually voltage) - The ratio of secondary to primary electrons emitted at each dynode depends on the energy of the incident photons and is controlled by inter-electrode potentials.

Changing the gain in the middle ranges does not change sensitivity, it just changes amplification

Offset – A residual background current at the anode is usually always present but can be subtracted. Some modern LSM's calibrate this automatically

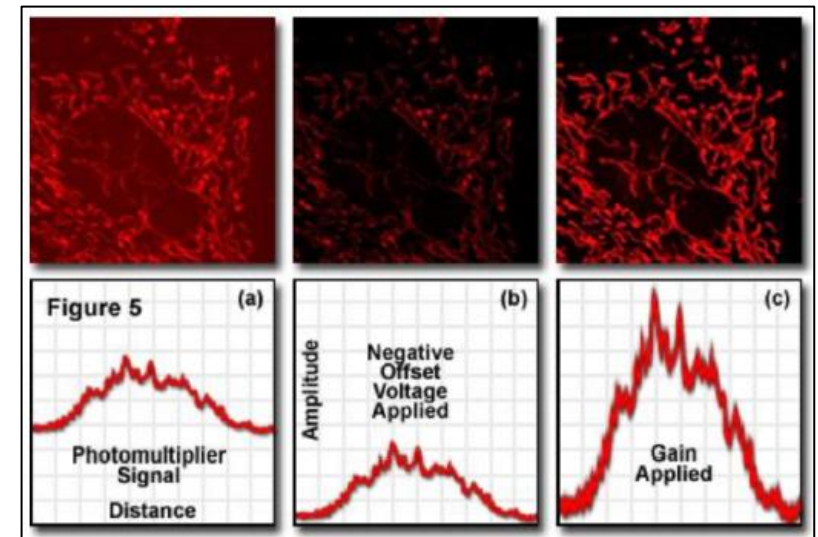
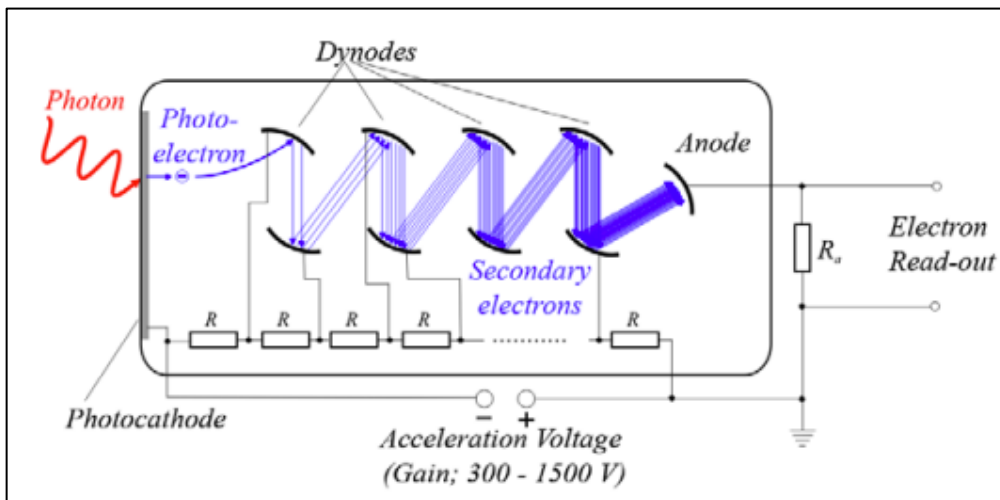

Refractive Index Matching

Matching the sample's refractive index to the immersion medium minimizes refraction and spherical aberration, improving light collection and image quality.

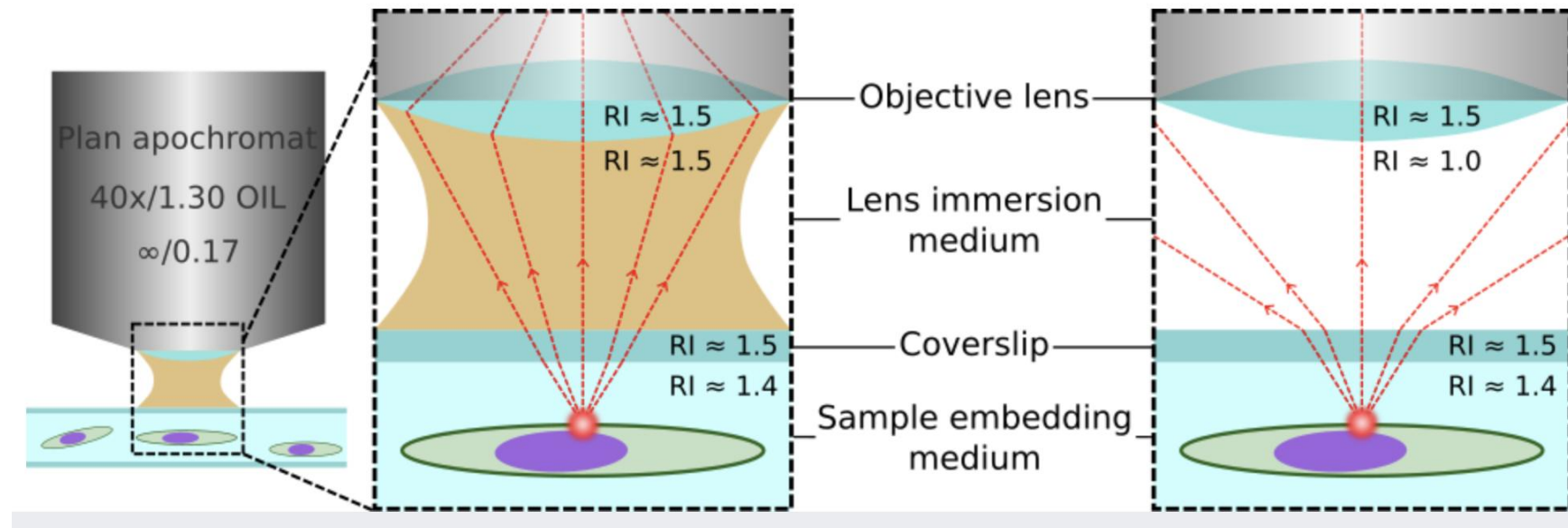

Adaptive Optics (AO)

Originally developed for astronomical imaging, AO can actively measure and correct for optical aberrations.

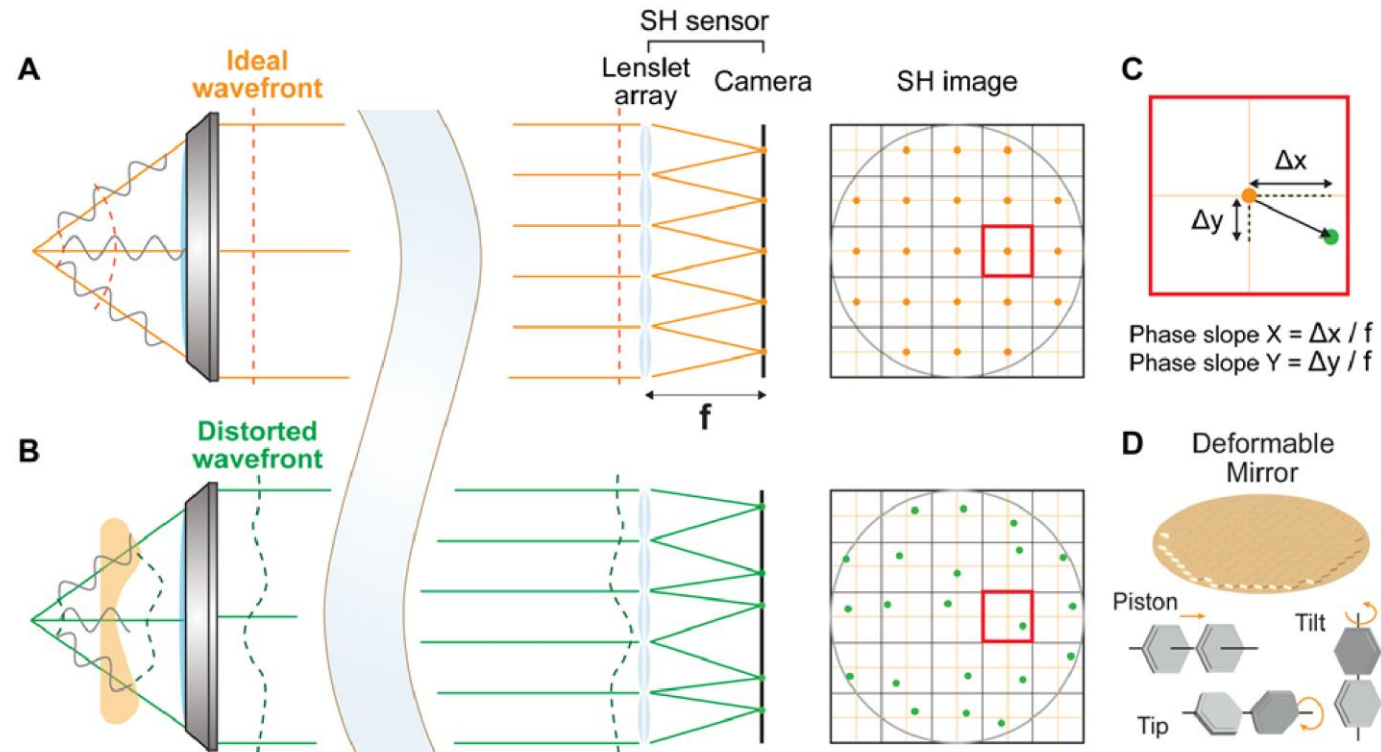

Zebrafish embryo brain

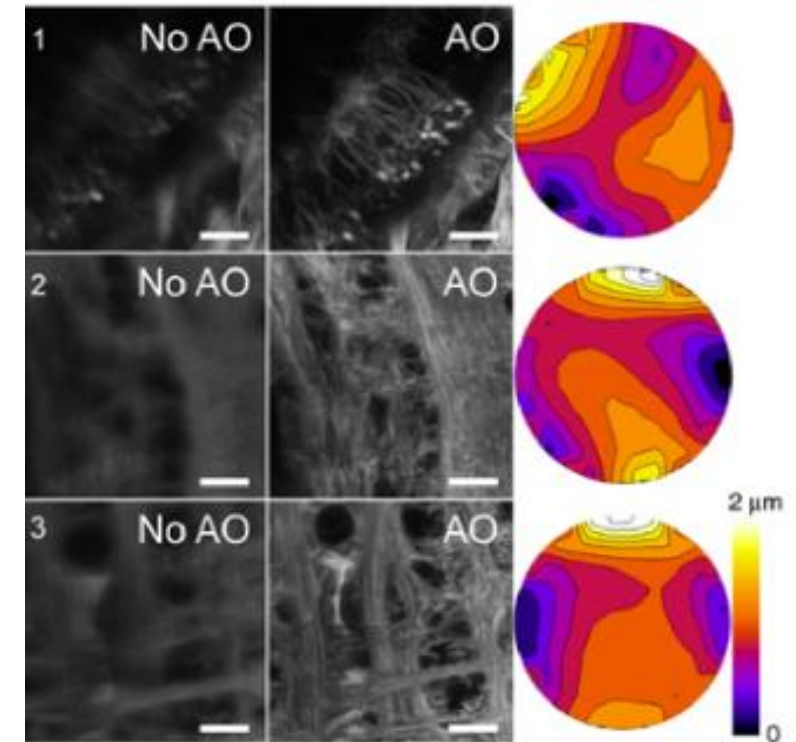

Applications with confocal microscopes

Applications: Spectral Imaging

The wavelength filtering system in confocal microscopes allow the characterization of the emission spectrum of a sample.

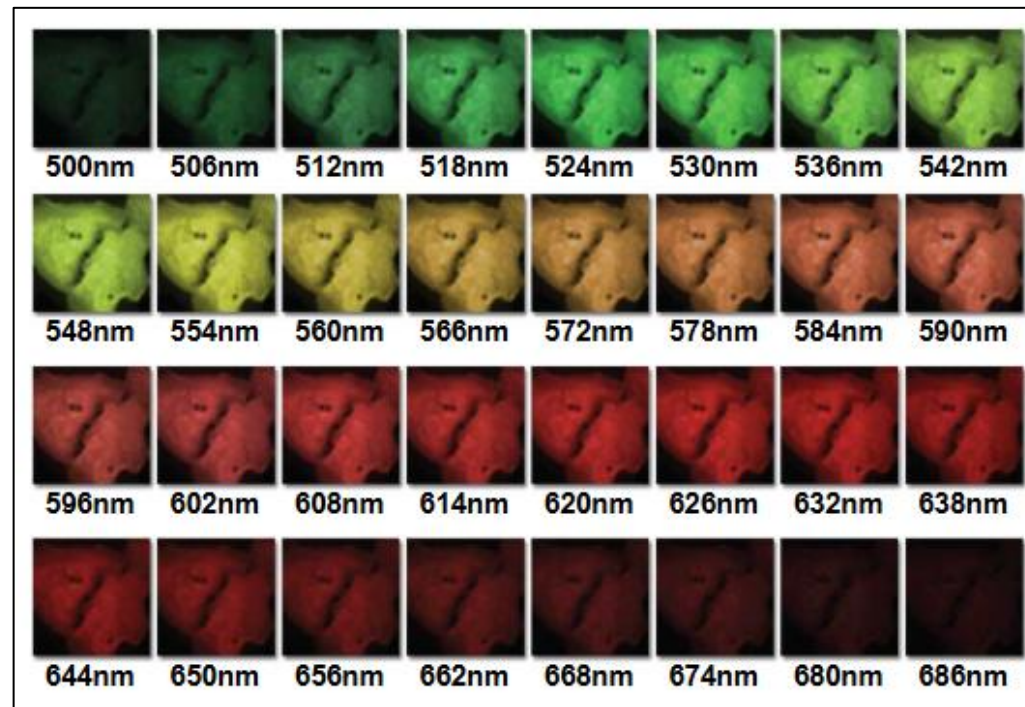

488 nm Excitation used

Applications: Spectral Imaging

The wavelength filtering system in confocal microscopes allow the characterization of the emission spectrum of a sample.

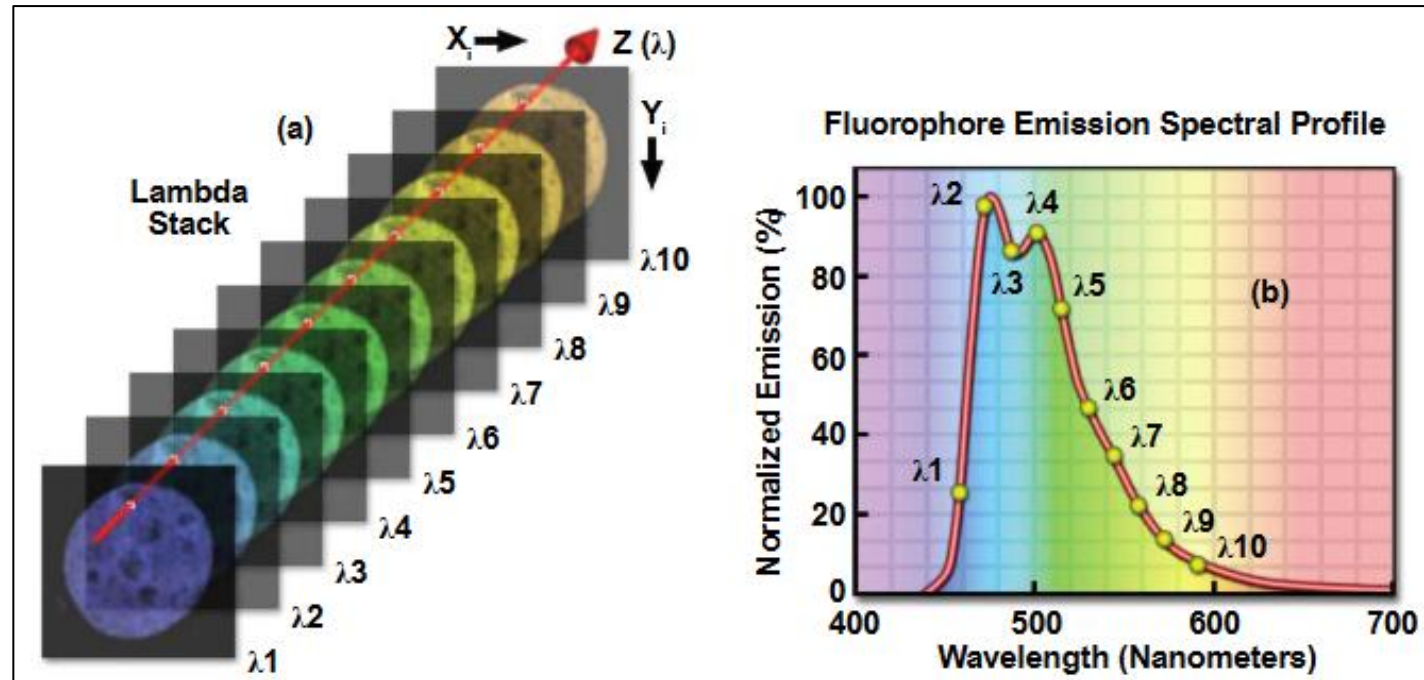

Applications: Spectral Imaging

However, two fluorophores like mKate2 and mCherry would be extremely difficult to separate using this approach

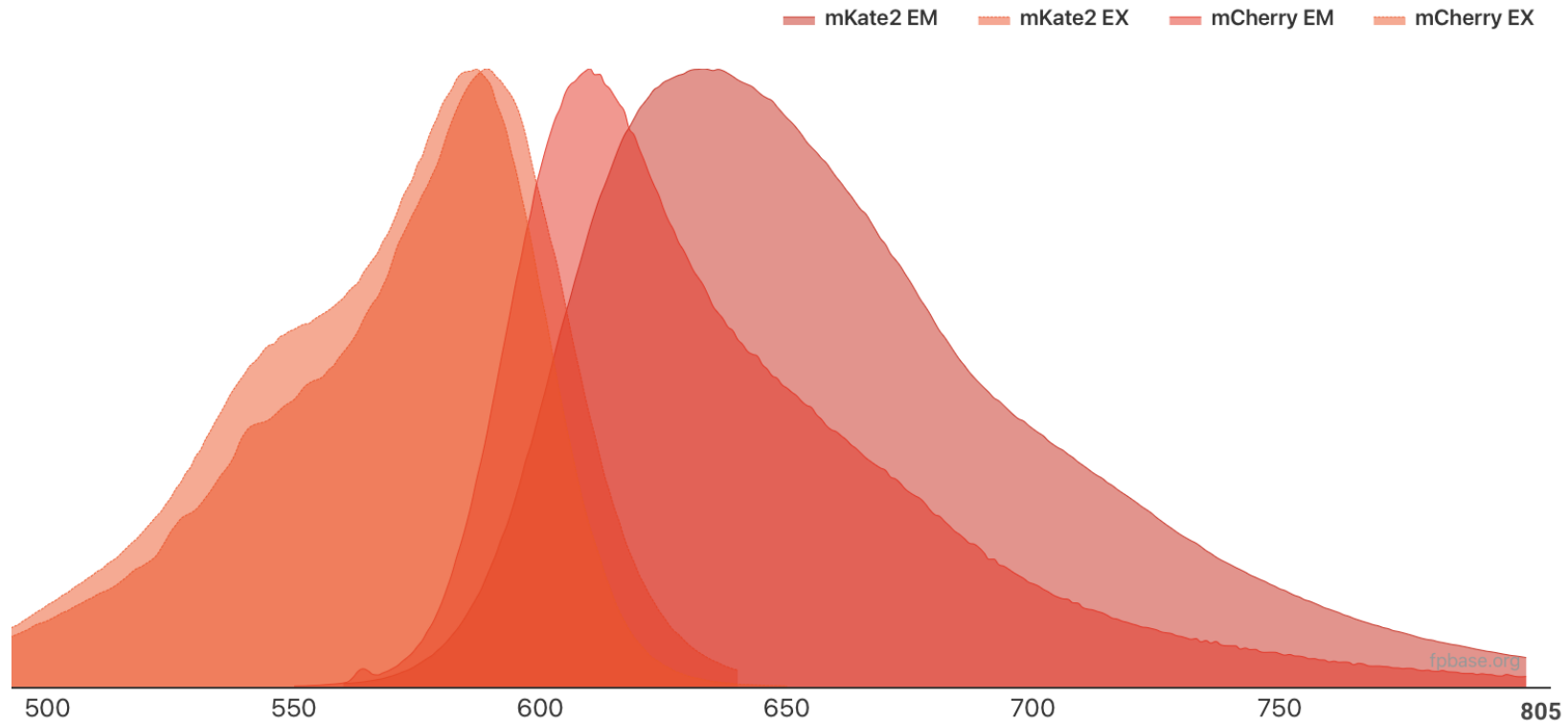

fpbase.org

Fluorescence Lifetime Imaging Microscopy (FLIM)

In FLIM, the signal from fluorophores can be separated based on their lifetime.

mCherry and mKate2

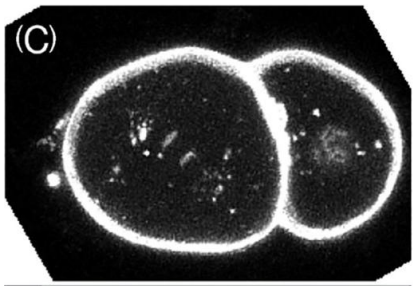

mCherry $\tau \sim 1.4-1.5$ nanoseconds

mKate2 $\tau \sim 2.5-2.6$ nanoseconds

mCherry subset

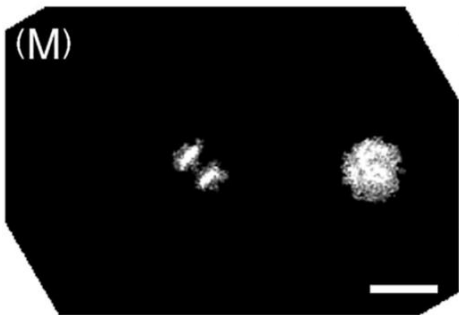

mKate2 subset

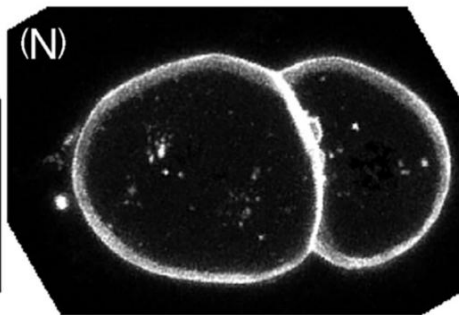

overlay of subsets

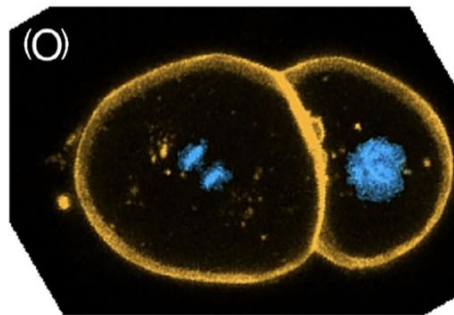

c. *Elegans* embryos

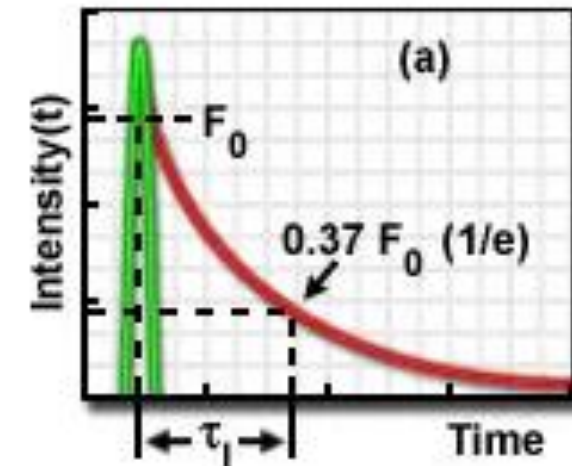
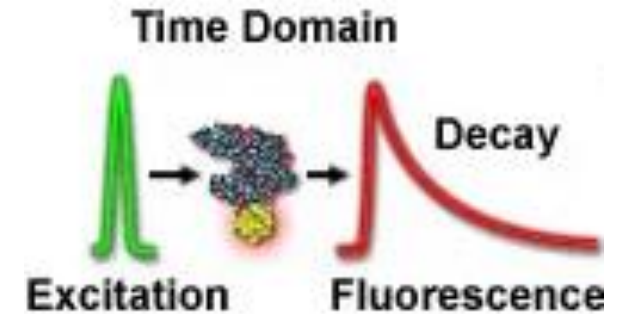

Applications: Mosaic/tile Imaging

To acquire high detailed images of large samples, contiguous fields can be imaged to be later merged using specialized software to stitch the image.

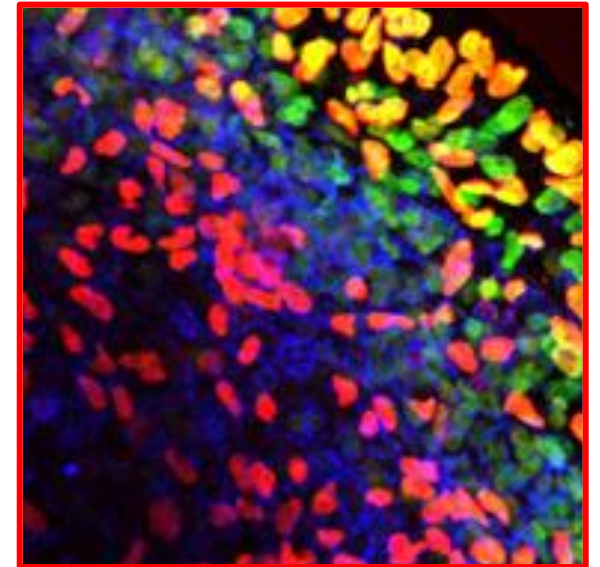
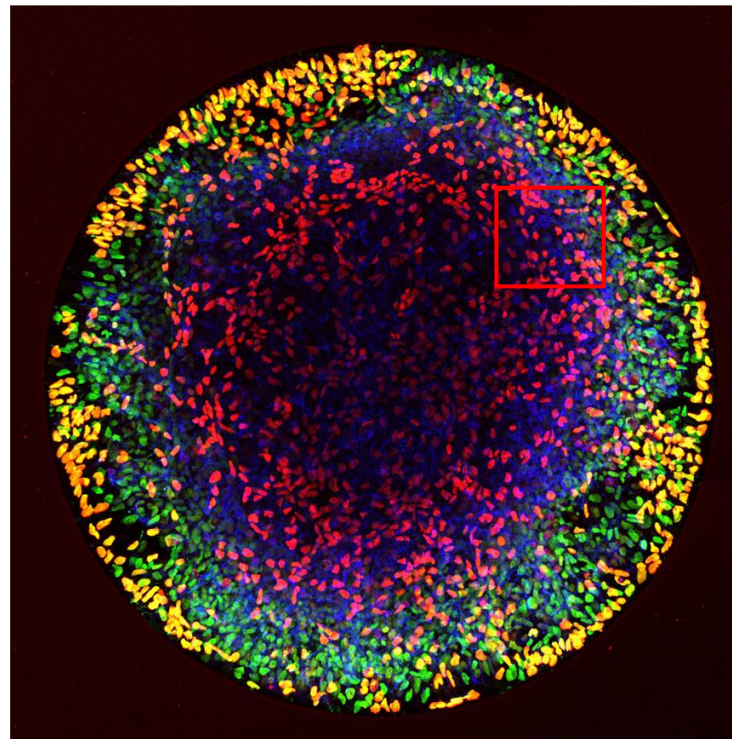
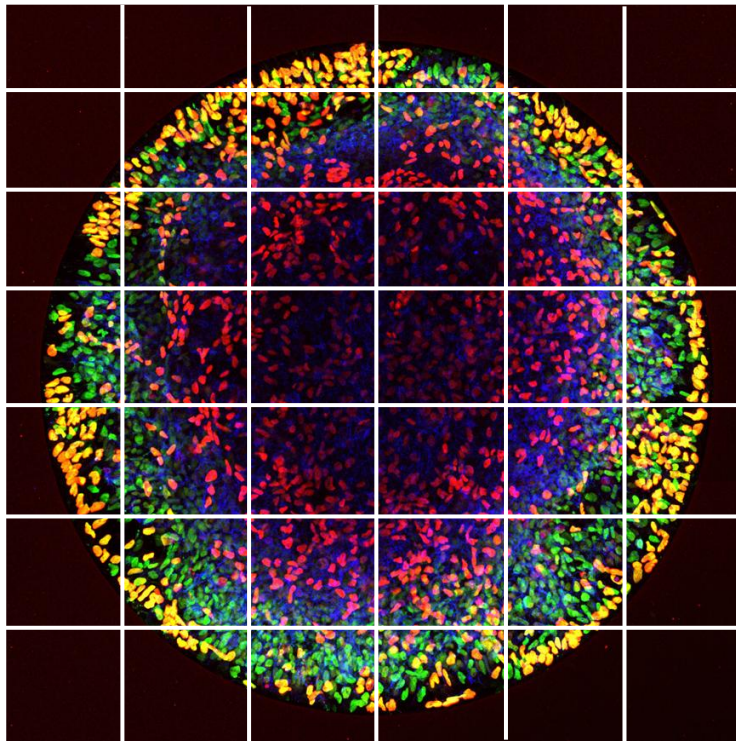

Gastruloid composed of different cell types – Brivanlou Lab.

The Battle of the Microscopes



The Battle of the Microscopes

	Strengths	Limitations
Point scanning Confocal	Excellent optical sectioning, ideal for thick samples (<100 um); Adjustable pinhole size; Specialized capabilities like spectral imaging.	Slower than camera-based systems; PMTs have low sensitivity, however GaAsp and APD detectors have increased quantum efficiency; High power excitation leads to higher photobleaching and phototoxicity.
Spinning Disk	Fast, gentle, ideal for live imaging.	Fixed pinhole geometry (Optimized for high mag lenses); crosstalk at thicker samples; less flexibility in scan pattern.

The Battle of the Microscopes

	Strengths	Limitations
Point scanning Confocal	Excellent optical sectioning, ideal for thick samples (<100 μm); Adjustable pinhole size; Specialized capabilities like spectral imaging.	Slower than camera-based systems; PMTs have low sensitivity, however GaAsp and APD detectors have increased quantum efficiency; High power excitation leads to higher photobleaching and phototoxicity.
Widefield Deconvolution Microscopy	Fast acquisition, high sensitivity, minimal specialized optics, ideal for thin samples with good SNR and accurate PSF.	Deconvolution artifacts if SNR/PSF poor; Less intrinsic optical sectioning; Poor for thick samples with diffuse signal.

Summary

- A confocal microscope allows to capture high contrast images by reducing the out of focus light.
- Adjustable dwell time and pinhole size let you trade resolution, speed, SNR, and photobleaching for each experiment.
- Think carefully if you really need confocal for your experiments! A widefield microscope may be faster and more sensitive to image a thin layer of cells at low magnification.
- To resolve different cellular structures or labelled molecules in the axial direction, optical sectioning is necessary (important for co-localization).

Thank you and enjoy the practical session!

Nice Confocal Lectures in Youtube:

- Microcourses – The confocal Principle:
<https://www.youtube.com/watch?v=rTkjQ6Q0p5I&t=461s>
- Salk Institute - Principles of Confocal Microscopy:
<https://www.youtube.com/watch?v=WZomCB10r5E>
- iBiology - Optical Sectioning and Confocal Microscopy:
<https://www.youtube.com/watch?v=1Q5V442V7xl&t=538s>
- OiVM – Introduction to Confocal Microscopy:
<https://www.youtube.com/watch?v=vn6app6Xull&t=529s>